

NORDIC LIBS 2026



AARHUS
UNIVERSITY
DEPARTMENT OF AGROECOLOGY

Nordic LIBS 2026

24-25 June 2026

Aarhus, Denmark

Content

Welcome	[1]
Organising Team	[2]
Full Program	[3]
Keynote Speakers	[6]
Invited Speakers	[7]
Regular Speakers	[8]
Poster Presentations	[9]
Sponsors	[10]
Aarhus and Venue	[11]
Cruise & Connect and Aarhus and Venue	[12]
Nordic LIBS 2024	[13]
Sponsor's Brochures	[14]
Abstracts (Talks)	[26]
Abstracts (Posters)	[61]

Welcome

Dear Colleagues,

Welcome to **Nordic LIBS 2026!**

We are delighted to host the 2nd edition of Nordic Laser-Induced Breakdown Spectroscopy (LIBS) symposium in Aarhus, Denmark, a leading university city and affectionately known as the '*City of Smiles*'. The event is scheduled to take place on June 24–25, 2026.

With around 70 participants from 18 countries, we anticipate that this event will represent a significant milestone, building on the success of the first Nordic LIBS Symposium held in Tampere, Finland, in March 2024. This is the only event in Northern Europe solely dedicated to LIBS.

The symposium offers a balanced scientific program, featuring keynote lectures by leading experts alongside innovative contributions from both academia and industry. We express our gratitude to all participants for sharing their research and presenting their latest accomplishments. We sincerely thank our invited and regular speakers, as well as sponsors, whose support is essential to the success of this event. We gratefully acknowledge the support from Aarhus University.

Thank you for being a part of our gathering. We hope you create lasting memories during your time in Aarhus.

Warm regards,

Symposium Chair

On behalf of the organising team

Organisers

CHAIR

[Prof. Mogens H. Greve](#)

Professor



CO-CHAIR &
SYMPOSIUM
DIRECTOR

[Dr. Vishal Dwivedi](#)

Postdoctoral Research Fellow



CO-CHAIR

[Dr. Maria Knadel](#)

Senior Consultant



Local Organising Team

LOGISTIC MANAGER

[Marzieh Zaresourmanabad](#)

SYMPOSIUM COORDINATORS

[Anne Heesche](#)

[Charlotte Hamann Knudsen](#)

[Friederike Malisch-Johnigk](#)

Full Program

Cruise & Connect

Tuesday, 23 June

Experience Aarhus from a new perspective

Join us for a cruise tour around Aarhus Harbour and enjoy the stunning views of the city from the waterside. From 22–24 June, Aarhus will host beautiful and historic tall ships from around the world as part of the Tall Ships Races Aarhus. This boat tour offers a unique opportunity to experience Aarhus from the water and see these impressive vessels up close.

Date and time Tuesday, 23 June 2026, **18:00 -19:15** (Please arrive 10 minutes before departure)

Departure point [Herman Sallings Plads 2, 8000 Aarhus C](#) (by the fountain)

Organiser [Aros Cruises](#)

Parking Available near Navitas, DOKK1, and Europaplads 16

Day 1

Wednesday, 24 June

08:30 Registration

09:00 Welcome **V. Dwivedi and M. H. Greve (DK)**

Session- 1

NELIBS

(Chair: M. H. Greve)

09:20 Keynote **A. De Giacomo (IT)**

Laser Induced Breakdown Spectroscopy: from on-flight applications to ultra trace analysis in lab with NELIBS

10:00

Coffee Break

Session- 2

Industry

(Chair: D. Prochazka)

10:25 Invited **R. Noll (DE)**

LIBS analyses for industrial applications – an overview of developments from 2019-2026

10:55 Oral **B. Klie (DE)**

Smart rubber extrusion: Using an “Inline” LIBS system as quality-relevant data input for an AI-based process control

11:15 Oral **A. Akram (NO)**

Industrial LIBS Based Sorting of Post-Consumer Wrought Aluminium Alloys for Automotive Applications

11:35 Oral **L. K. Tinoco Navarro (CZ)**

Lightigo LIBS solutions, Challenges and Emerging Applications in Environmental and Industrial Systems

11:55 Sponsor **D. Adén (DK)**

Elemental abundance analysis for agricultural samples using Laser Induced Breakdown Spectroscopy – Adopting LIBS for commercial laboratories (FOSS Analytical A/S)

12:10

Lunch Break

Session- 3

Sponsors

(Chair: T. Aaltonen)

13:00 Sponsor **S. Rapp (DE)**

InnoLas Laser GmbH

13:15 Sponsor **P. Bennett (FR)**

Lumibird

13:30 Sponsor **J. Fellingner (AT)**

MONTFORT Laser GmbH & Co KG

13:45 Sponsor **P. Ziedelis (LT)**

Quantum light instruments

14:00 Sponsor **L. Favé (DE)**

Edmund Optics GmbH

14:15 Sponsor **H. Taylor (NL)**

Photonics Industries Europe, BV

14:30 Sponsor **R. B. Sterobo (DK)**

Ibsen Photonics

Full Program

14:45	Coffee Break & Group Photo	
Session- 4	Nuclear Fusion & CF-LIBS	(Chair: V. Dwivedi)
15:15	Invited	P. Veis (SK) <i>LIBS for the Analysis of Fusion-Relevant Plasma-Facing Components</i>
15:45	Invited	P. Gašior (PL) <i>Automated ML-based tool for spectra reconstruction, processing and visualization for LIBS data obtained in LIBS @JET experiment</i>
16:15	Oral	A. Hakola (FI) <i>Demonstration of LIBS as a tritium monitoring tool in fusion reactors</i>
16:35	Oral	C. Gerhard (DE) <i>Quantification of impurities in different oxides via calibration-free LIBS</i>
16:55	Oral	S. Soni (DE) <i>Influence of Structured Laser Beam Profiles on Ablation Dynamics and Analytical Performance in LIA-QMS</i>
17:15	Poster Session	
18:15	Free time	
18:30	Bus from symposium venue to dinner place	
19:00	Symposium Dinner Place: Salling Rooftop Aarhus Address: Søndergade 27, 8000 Aarhus (Google Map)	
<i>The dinner will take place at Salling Rooftop Aarhus. This vibrant rooftop space offers a spectacular urban setting with a stunning 360-degree panoramic view of the entire city. You can enjoy not only the impressive views but also a delightful dinner in a unique and relaxed environment - making it the perfect place to create unforgettable memories during Nordic LIBS 2026.</i>		
Day 2	Thursday, 25 June	
Session- 5	Environment	(Chair: P. Jorge)
09:00	Keynote	J. Kaiser (CZ) <i>LIBS Bioimaging: A Comprehensive Overview from Environmental Monitoring to Plant Growth Beyond Earth</i>
09:40	Oral	M. Knadel (DK) <i>Laser-Induced Breakdown Spectroscopy for Soil Characterisation: Status of Aarhus University Research</i>
10:00	Coffee Break	
Session- 6	Applied LIBS	(Chair: P. Veis)
10:25	Invited	V. Motto-Ros (FR) <i>How Far Can LIBS Imaging Go? A Journey Across Scales</i>
10:55	Oral	J. Toivonen (FI) <i>Analysis of single particles for aerosol research and water monitoring</i>
11:15	Oral	K. Kinch (DK) <i>Challenges when operating a commercial LIBS instrument in the far UV</i>
11:35	Oral	M. Szoltysik (SE) <i>Elemental Scientific</i>
11:50	Sponsor	S. Merk (DE) <i>CRM Inhomogeneity – Impact on LIBS Calibration (LTB Lasertechnik Berlin)</i>
12:05	Lunch Break	

Full Program

Session- 7		Imaging & ANN	(Chair: J. Toivonen)
13:00	Invited	P. Pořizka (CZ) <i>Multimodal imaging for the analysis of stroke and cancer</i>	
13:30	Oral	C Derrick Quarles Jr (USA) <i>High-Speed KHz LIBS Imaging</i>	
13:50	Oral	T. Aaltonen (FI) <i>Neural Networks in LIBS: Perspectives, Challenges, and Opportunities</i>	
14:10	Oral	D. Prochazka (CZ) <i>Physics-Informed Neural Network for Qualitative Element Detection from Spark Discharge Optical Emission Spectra</i>	
14:30	Sponsor	J. Kodz (ES) <i>MONOCROM S.L.</i>	
14:45	Coffee Break		
Session- 8		Imaging & Plants	(Chair: P. Pořizka)
15:10	Invited	P. Jorge (PT) <i>Multimodal Spectral Imaging as an Enabler of Digital Twins of Complex Systems</i>	
15:40	Oral (short)	F. Mikkelsen (DK) <i>Recalibration of PLS models to enable quantification of low concentration plant nutrients by laser induced breakdown spectroscopy</i>	
15:50	Oral (short)	D. Sonoiki (DK) <i>How should detection limits be defined in LIBS?</i>	
16:00	Sponsor	J. McDowell (GB) <i>Litron Lasers Ltd</i>	
16:15	Closing		

Keynote Speakers

Prof. Alessandro De Giacomo

*Department of Physics and Applied Physics, University of Massachusetts, Lowell, USA
Department of Chemistry, University of Bari, Italy
Institute of Photonics and Nanotechnologies, Italy*



Title: Laser Induced Breakdown Spectroscopy: from on-flight applications to ultra trace analysis in lab with NELIBS

Prof. Giacomo is a distinguished expert in laser-matter interactions and analytical spectroscopy. He holds a professorship in General Chemistry, Quantum Chemistry, and Plasma Chemistry at the University of Bari in Italy and also serves at the Institute of Photonics and Nanotechnology of the National Council of the Researchers (CNR-IFN) as an associated researcher. In addition, he serves as an Affiliate Professor of the Department of Physics and Applied Physics at the University of Massachusetts in Lowell and a permanent staff member of the inter-university research consortium devoted to basic research and to the development of high-tech new processes in several different scientific fields of Chemistry.

His research has been focused on fundamental studies of laser induced plasmas in different applications ranging from material science to analytical chemistry, such as laser spectroscopy, nanoparticle (NP) and carbon nanostructure synthesis by pulsed laser ablation in liquid (PLAL), laser induced breakdown spectroscopy (LIBS) etc. Prof. Giacomo is an active member of a number of scientific committees of international conferences and editorial boards of international journals, and a reviewer of several funding agencies in Europe, North America and Asia. Since 2017 he is serving as the chief editor of *Spectrochimica Acta Part B Atomic Spectroscopy*, an Elsevier journal. His extensive publication record includes hundreds of scientific articles with approximately 9000 citations and an h-index around 50, reflecting his sustained impact on analytical chemistry and laser spectro-chemical diagnostics.

Prof. Jozef Kaiser

CEITEC, Brno University of Technology, Czech Republic



Title: LIBS Bioimaging: A Comprehensive Overview from Environmental Monitoring to Plant Growth Beyond Earth

Prof. Kaiser is a distinguished physicist specializing in advanced analytical techniques, including LIBS, Laser-Induced Fluorescence (LIF), X-ray micro-/nano-tomography, and a broad spectrum of spectroscopic methods. He heads the Advanced Instrumentation and Methods for Materials Characterization group and Laser Spectroscopy group at the CEITEC, Brno. Alongside his academic contributions, he maintains active collaborations with industry partners such as Lightigo s.r.o. and Cactux s.r.o., effectively bridging fundamental research and real-world applications.

Prof. Kaiser is an esteemed member of several international spectroscopy societies and has played a key role in advancing LIBS research both in the Czech Republic and across the global scientific community. He has an extensive publication record, having authored or co-authored approximately 500 scientific articles that have collectively garnered around 10,000 citations, corresponding to an h-index of 54 (Google Scholar), underscoring his longstanding contribution on analytical spectroscopy and laser-based diagnostics.

Invited Speakers

Prof. Reinhard Noll

LSA – Laser Analytical Systems & Automation, Germany

Title: LIBS analyses for industrial applications – an overview of developments from 2019-2026



Prof. Pavel Veis

Department of Experimental Physics, FMFI, Comenius University, Slovakia

Title: LIBS for the Analysis of Fusion-Relevant Plasma-Facing Components



Asst. Prof. Paweł Gašior

Institute of Plasma Physics and Laser Microfusion (IPPLM), Warsaw, Poland

Title: Automated ML-based tool for spectra reconstruction, processing and visualization for LIBS data obtained in LIBS @JET experiment



Assoc. Prof. Vincent Motto-Ros

Institut Lumière Matière, Université de Lyon, France

Title: Pushing the Limits of LIBS: Toward True Micrometer-Scale Imaging?



Assoc. Prof. Pavel Pořízka

CEITEC, Brno University of Technology, Czech Republic

Title: Multimodal imaging for the analysis of stroke and cancer



Prof. Pedro Jorge

Centre of Applied Photonics, INESC TEC

Departamento de Física e Astronomia, Faculdade de Ciências, Universidade do Porto, Portugal

Title: Multimodal Spectral Imaging as an Enabler of Digital Twins of Complex Systems



Regular Speakers

Dr.-Ing. Benjamin Klie

Deutsches Institut für Kautschuktechnologie e. V., Germany

Md. Ali Akram

Norwegian University of Science and Technology (NTNU), Norway

Dr. Lizeth Katherine Tinoco Navarro

Lightigo s.r.o, Brno, Czech Republic

Antti Hakola

VTT Technical Research Centre of Finland Ltd, Finland

Prof. Christoph Gerhard

University of Applied Sciences and Arts, Göttingen, Germany

Dr. Shweta Soni

Max Planck Institute for Plasma Physics, Garching, Germany

Dr. Maria Knadel

Department of Agroecology, Aarhus University, Denmark

Prof. Juha Toivonen

Photonics Laboratory, Tampere University, Finland

Dr. Kjartan Bergeron Kinch

Foss Analytical, Denmark

C Derrick Quarles Jr, PhD

Elemental Scientific Inc., Omaha, Nebraska, USA

Toni Aaltonen

Satakunta University of Applied Sciences, Finland

Dr. David Prochazka

Central European Institute of Technology (CEITEC), BUT, Brno, Czech Republic

Frederikke Mikkelsen

Foss Analytical & University of Copenhagen, Denmark

Dr. Doyinsola Sonoiki

Technical University of Denmark, Denmark

Poster Presentations

No.	First Name	Last Name	Affiliation	Title
P1	S Md Ali	Akram	NTNU, NO	<i>Industrial LIBS Based Sorting of Post-Consumer Wrought Aluminium Alloys for Automotive Applications</i>
P2	S Octavio	Crovo	UNIBA, SK	<i>Elemental Identification and Quantification of Recycled Steel Samples Using LIBS</i>
P3	S Lucie	Holcmanova	CEITEC, CZ	<i>Pilot study on Detection of Thermochemical Degradation in Thermally Modified Wood</i>
P4	S Frederikke	Mikkelsted	FOSS, DK	<i>Recalibration of PLS models to enable quantification of low concentration plant nutrients by laser induced breakdown spectroscopy</i>
P5	S Saquib	Anjum	Uni. Bayreuth, DE	<i>LIBS-based detection of metals in lubricating oils</i>
P6	S Eetu	Ojanen	Unaffiliated	<i>Geometry-aware radiative-transfer modeling of LIBS spectra with ray bundles in a layered LTE plume</i>
P7	S Tomás	Lopes	INESCTEC, PT	<i>Self-Supervised Latent Space Learning for LIBS Spectroscopy</i>
P8	Joonas	Rouhiainen	SAMK, FI	<i>Micro-discharge system for OES training data collection</i>
P9	Yilin	Wang	SAMK, FI	<i>An Interactive Online Platform for the Simulation and Analysis of LIBS</i>
P10	Christoph	Gerhard	HAWK, DE	<i>'Laserless LIBS' – Dielectric barrier discharge plasma-induced emission spectroscopy (DBD-IES)</i>
P11	Krystof	Polak	CRYTUR, CZ	<i>ESTER: A 60 mJ Compact Air-Cooled Q-Switched Nd:YAG Laser for Field Deployment</i>
P12	Giedrius	Kudaba	Ekspla, LT	<i>Laser sources for LIBS applications</i>
P13	Lizeth Katherine	Tinoco Navarro	Lightigo, CZ	<i>Lightigo LIBS solutions, Challenges and Emerging Applications in Environmental and Industrial Systems</i>
P14	Shweta	Soni	MPG, DE	<i>Influence of Structured Laser Beam Profiles on Ablation Dynamics and Analytical Performance in LIA-QMS</i>
P15	Doyinsola	Sonoiki	DTU, DK	<i>How should detection limits be defined in LIBS?</i>
P16	Sanja	Živković	VIN, RS	<i>Utilization of 3D-printed support for LIBS analysis of liquids</i>
P17	Sahithya	Atikukke	UNIBA,SK	<i>Depth-Resolved Detection of Deuterium in Tungsten-Based Materials Using High-Resolution LIBS</i>
P18	Parviz	Elahi	OZYEGIN, TR	<i>LIBS at nJ Pulse Energy with GHz repetition rate, burst mode Yb fiber laser</i>
P19	Jeannet	Meima	BGR, DE	<i>Challenging LIBS matrix effects in Cu-rich raw materials; quantification with multivariate calibration and CF-LIBS</i>
P20	Vishal	Dwivedi	AU, DK	<i>LIBS Analysis of Heavy Metal in Lipsticks: Advancing Cosmetic Safety Standards</i>
P21	Vishal	Dwivedi	AU, DK	<i>Phosphorus prediction in agricultural soils using LIBS</i>

Sponsors



Aarhus



Aarhus, Denmark's second-largest city and affectionately known as the 'City of Smiles', offers a seamless blend of modern architecture, historic neighbourhoods, and relaxed Scandinavian charm. Founded by the Vikings in the 8th century, the city is set along a natural bay and a small river, surrounded by forests, beaches, and scenic coastal paths. As the cultural heart of Denmark, Aarhus offers iconic attractions such as [Den Gamle By](#) open-air museum, the waterfront [Dokk1](#) cultural center, and the world-renowned [ARoS Art Museum](#) with its colourful rainbow panorama. With nearly one-fifth of its residents being students, Aarhus is often called the youngest and brightest city in Denmark, giving it a lively atmosphere filled with cafés, boutique shops, and a vibrant harbor.

Venue



The [Nordic LIBS 2026](#) symposium is scheduled to be held at the **Conference Center [Stakladen](#)** of Aarhus University.

Address: Building 1423/111, [Fredrik Nielsens Vej 2-4, 8000 Aarhus C](#)

Cruise & Connect



Join us for a cruise tour around Aarhus Harbour and enjoy the stunning views of the city from the waterside. From 22–24 June, Aarhus will host beautiful and historic tall ships from around the world as part of the Tall Ships Races Aarhus. This boat tour offers a unique opportunity to experience Aarhus from the water and see these impressive vessels up close.

Date and time Tuesday, 23 June 2026, **18:00 -19:15**
Departure point [Herman Sallings Plads 2, 8000 Aarhus C](#) (by the fountain)
Organiser [Aros Cruises](#)

Symposium Dinner

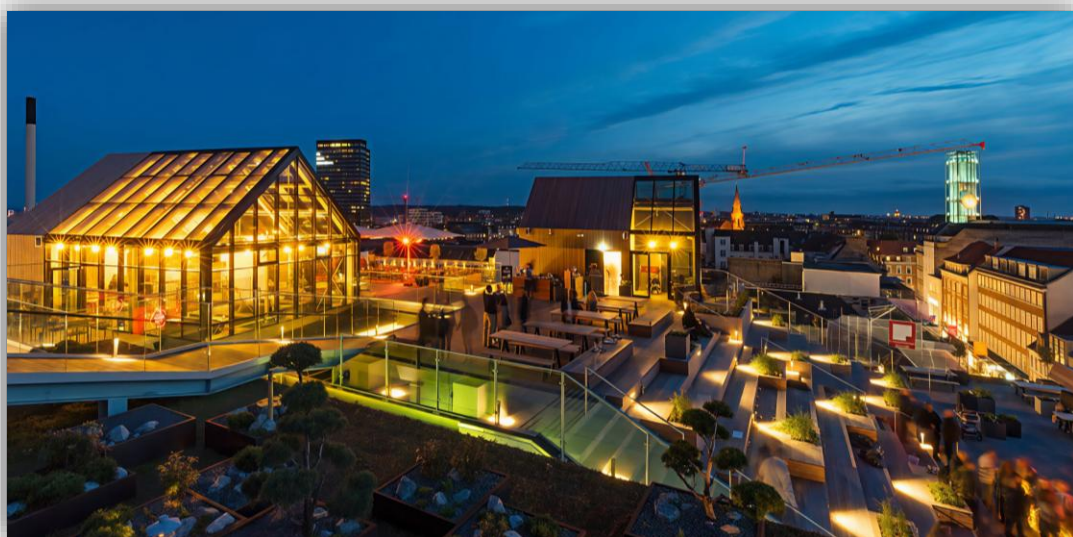

The symposium dinner will take place at [Salling Rooftop Aarhus](#). This vibrant rooftop space offers a spectacular urban setting with a stunning 360-degree panoramic view of the entire city. You can enjoy not only the impressive views but also a delightful dinner in a unique and relaxed environment - making it the perfect place to create unforgettable memories during Nordic LIBS 2026.

Date and time Wednesday, 24 June 2026, **19:00** onwards
Place [Salling Rooftop Aarhus](#) Address: [Søndergade 27, 8000 Aarhus](#)

A look back: Nordic LIBS 2024



Nordic LIBS 2024

5-6 March, 2024
Tampere, Finland

Organisers

Dr. Vishal Dwivedi

Dr. Jan Viljanen

Prof. Juha Toivonen

Applied Optics Group, Tampere University, Finland

Spectrometers



Compact and high-resolution echelle spectrometer series for scientific and industrial applications

- f/7-f/10
- 5,000-50,000 ($\lambda/\Delta\lambda$ FWHM)
- 50-5 pm ($\lambda/\Delta\lambda$ R) at 250 nm
- 190-1,070 nm (λ max range)
- max. 740 nm (λ simul)

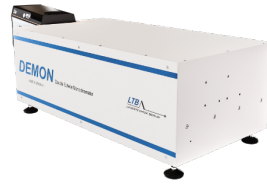

Very high-resolution and optical throughput echelle spectrometer for isotope spectroscopy and laser quality control

- f/10
- 60,000-200,000 ($\lambda/\Delta\lambda$ FWHM)
- 3.3-1.3 pm ($\lambda/\Delta\lambda$ R) at 250 nm
- 190-1,700 nm (λ max range)
- 1-13.5 nm (λ simul)



Worldwide unique echelle spectrometer series for the spectral characterization of emission and absorption lines

- f/50
- 1 million-6.5 million ($\lambda/\Delta\lambda$ FWHM)
- 78-30 fm ($\lambda/\Delta\lambda$ R) at 193 nm
- 190-1,100 nm (λ max range)
- 8-400 pm (λ simul)

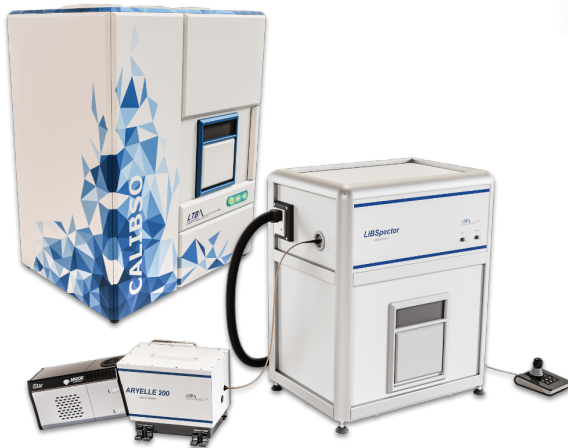

Analysis Systems

Laser based elemental and molecular analysis with LIBS and Raman

- High-quality sample imaging with micrometer sized resolution, single spot measurement or area scans
- High-resolution echelle spectrometer with spectral resolving power in the pm-range and a large simultaneous wavelength range
- Material identification, classification and quantification of bulk materials or surfaces with univariate or multivariate data analysis
- Rapid material analysis in many fields e.g. technical cleanliness, forensics, geology and battery research

Lasers

DPSS Lasers with active q-switch

- Wavelength: 1064 nm (336 nm / 355 nm available)
- Pulse energy: >1.5 mJ
- Pulse length: 3.5 ns
- Repetition rate: 1 kHz down to single pulse

Nitrogen-Lasers with sealed discharge cartridge

- Wavelength: 337 nm
- Up to 200 μ J pulse energy
- Extremely long operating life time
- High precision through a directly switching solid state power switch
- Warranty up to 400 million pulses
- Application e.g.: MALDI-TOF, LIF

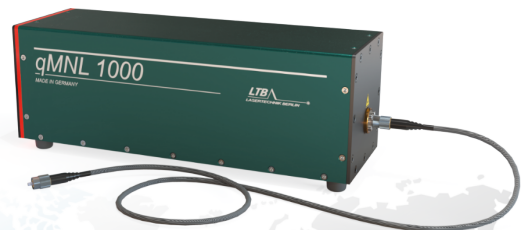

**Ultrafast
Specialty
Lasers**

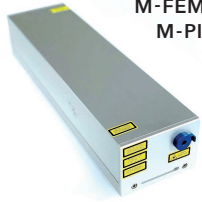

M-FEMTO
M-PICO

**Uniquely
Compact
Nanosecond
Lasers**

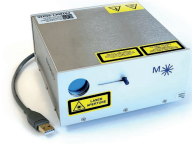

M-NANO
>120mJ | <8ns | <2kg

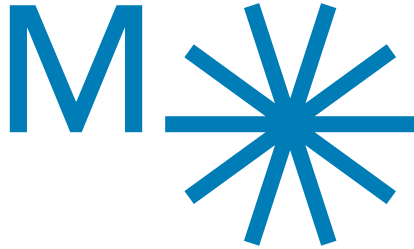

**Montfort™
Laser**

www.montfortlaser.com

M-NANO

up to >200mJ | <10ns | 2.5 kg



**LIBS
LIDT
PIV
PHOTO
ACCOUSTICS**

...



Micral™

Accelerate your element analysis



ANALYTICS BEYOND MEASURE

Micral™ speeds up test capacity and provides valid results for key elements such as calcium, magnesium, phosphorus and more in only one minute per sample. Say goodbye to chemicals and complicated methods and deliver many more results quickly, sustainably, and profitably.

Let real-time data support your decisions

Get accurate data about mineral composition of the livestock basal diet and adjust mineral levels for optimal growth and performance. Fast results and low cost enables regular testing throughout the year, reducing overuse and environmental impact of feed additives. You can also test plant leaf tissue to guide crop nutrition and optimize yield.

Speed up operations

Get precision quantitative testing of 6 macro and 6 micro elements, with no use of chemicals and without the need for special training. Increase time to result and reduce cost per sample with the autosampler cassette, allowing analysis of 60 samples in one go.

Automate for better flow

Benefit from ready-to-use analytics packages, traceable results with sample ID barcode and digital tools to develop and expand analytics for other matrices, including plant leaf tissue.

Sample types

Grass silage, corn silage, alfalfa/legume hay, hay, fresh grass, haylage, mixed hay, sorghum, straw, grass and clover and barley silage (whole crop silage), plant leaf tissue (corn, wheat, soy).

Parameters

6 macro elements: calcium (Ca), magnesium (Mg), phosphorus (P), potassium (K), sodium (Na), sulphur (S).

6 micro elements: aluminum (Al), boron (B), copper (Cu), iron (Fe), manganese (Mn), zinc (Zn).

Technology

Laser Induced Breakdown Spectroscopy (LIBS).

Q2

Q2 series diode pumped, fully air-cooled, Q-switched laser designed for wide range of applications that require high peak power pulses.

Our innovative water-free laser crystal end-pumping technology allows to produce Gaussian-like, low divergence laser beam. At the same time, Q2 is versatile platform that can be configured in many ways.

FEATURES

- **1053 nm** or **1064 nm** wavelength from Nd:YLF or Nd:YAG laser crystals respectively
- **Up to 80 mJ** pulse energy
- **Up to 2 W** average output power
- **Up to 100 Hz** variable pulse repetition rate
- **Air cooled (water-free)**
- **5-10 ns** pulse duration. (Optional <3 ns pulse duration at up to 40 mJ pulse energy (short cavity version))
- **Weight < 9 kg** incl. heatsink, controller & AC/DC adapter
- **> 2 G shots** lifetime of pump diode
- **Built-in sync pulse generator** for triggering of user equipment
- Remote monitoring and **control via built-in Ethernet** interface

OPTIONAL EXTENSIONS

Stand alone:

- **2nd, 3rd, 4th or 5th** harmonic generator
- **Two-channel pulse generator** for triggering
- **Air-purging** unit for long lifetime of UV optics

Attachable:

- **2nd** harmonic generator SHG
- **2 - 3 ns pulse duration** at up to 60 mJ pulse energy (short cavity version)
- PC controlled **motorized attenuator** for fundamental wavelength beam
- **Beam guiding** module
- **Pulse energy monitor** with analog and/or digital output

Fiber coupled output

APPLICATIONS

- Light Detection And Ranging (LIDAR) (Metrology, Military, Astronomy ant etc.)
- Spectroscopy (Laser Induced Breakdown (LIBS), Light Induced Fluorescence (LIFS), Flash photolysis and etc.)
- Laser ablation (marking, LCD repair, trimming, etc.)
- Medical (Ophthalmology, Dermatology, Photoacoustic Imaging (PAI) and etc.)
- Pulsed Laser Deposition (PLD)

DIODE PUMPED AIR-COOLED Q-SWITCHED LASER

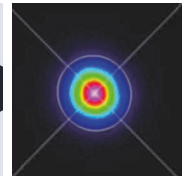
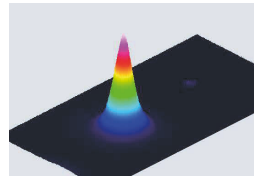
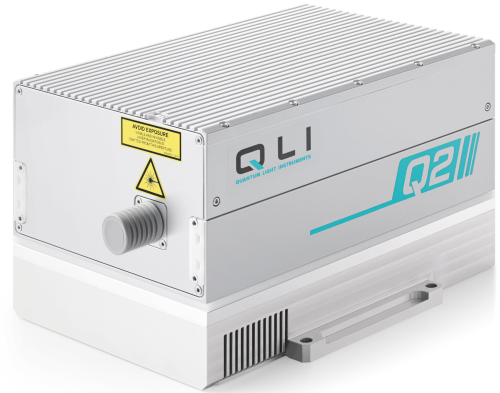

Effective Diameter: 1931.4 μm

Ellipticity: 97.2 %

Beam profile Q2-B10 @1064 nm

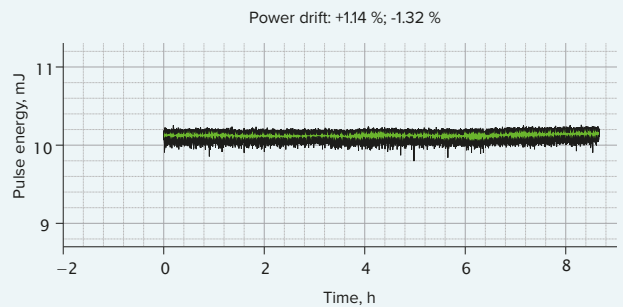

Long term stability Q2-B10 @1064 nm

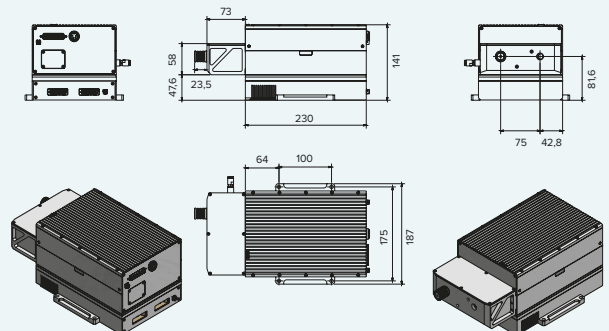

Q2 laser head and SHG module drawings

imageGEO193

High-speed, high-resolution imaging

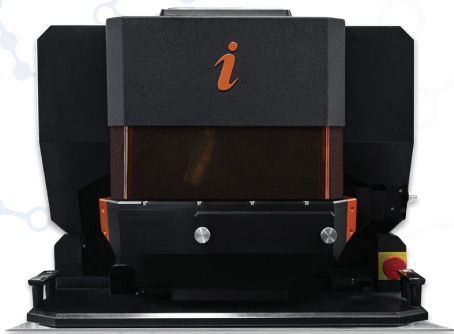

One-Piece DCI Dual Concentric Injector



TwoVol3

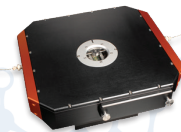

Time-Resolved Software



Elemental Insight
High-speed Elemental Imaging



1.75 million pixels/hour

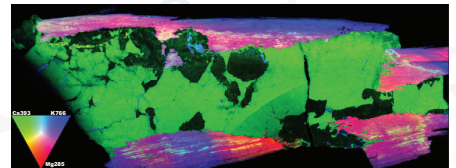

Granitic Pegmatite

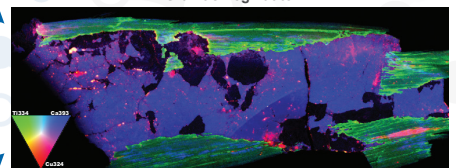

6 cm

18 cm



ESLumen
LIBS-ICPMS

Sand Tiger Shark Teeth

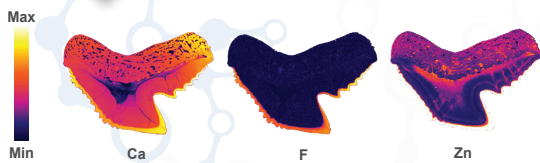

icpmslasers.com

Design and manufacture of the world's best gratings & spectrometers



When efficiency matters

www.ibsen.com

Spectrometers for Raman Spectroscopy

- Resolution and bandwidth
8.5 cm⁻¹ over 0-5136 cm⁻¹
5.8 cm⁻¹ over 0-3480 cm⁻¹
6.3 cm⁻¹ over 200-3650 cm⁻¹
- Polarization independent gratings
- High throughput and high sensitivity
- Compact design: Down to 125x139x60 mm



EAGLE Raman HR

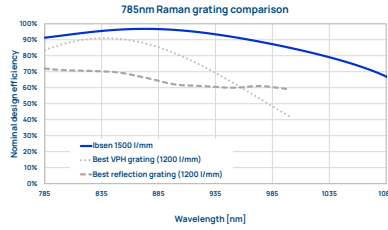

Application example

Spectrometers for Optical Coherence Tomography

- Bandwidth, axial resolution & depth (in air)
 $\Delta\lambda$ 40nm, 9.2 μ m, 9.0 mm
 $\Delta\lambda$ 90nm, 4.1 μ m, 4.0 mm
 $\Delta\lambda$ 140nm, 2.7 μ m, 2.6 mm
- Frame rate options: 20-250 kHz
- Superior roll-off performance
- Variable center wavelength



EAGLE OCT-S-40

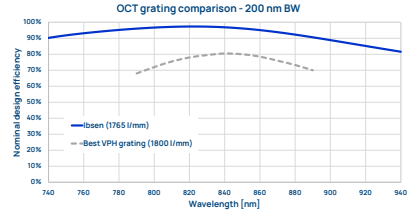

Application example

Low Light Raman Spectroscopy

- Extremely stable (< 0.01 nm/°C)
- High NA (0.3) for highest sensitivity
- 3mm tall slit for maximum throughput
- Example product: EAGLE Raman-S



Compact, Cost-effective SD-OCT

- Ultra compact 130x75x36 mm
- MIPI CSI-2 interface, 12 bit, 2048 pixel
- Frame rate 61 to 101 kHz
- Example product: EAGLE C-OCT-S-90



Spectrometers for NIR Spectroscopy

- Resolution: Down to 3.3 nm
- Wavelength range
900-1700 nm (NIR)
1100-2100 nm (XNIR)
- 1 or 2 stage TE cooling
- Compact design: Down to 23x21x8 mm



ROCK NIR

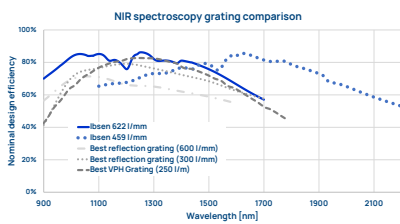

Application example

Spectrometers for VIS / VIS-NIR Spectroscopy

- Resolution: Down to 0.3 nm
- Wavelength range:
360-830 nm (VIS)
475-1100 nm (VIS-NIR)
190-850 nm (UV-VIS)
- Compact design: Down to 20x15x8 mm



ROCK VIS

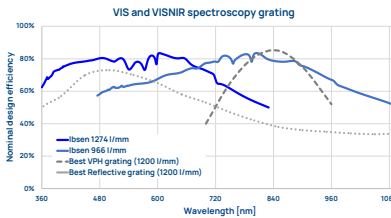

Application example

Spectrometers for UV / UV-NIR Spectroscopy

- Resolution: Down to 0.15 nm
- Wavelength range:
173-409 nm (DUV)
190-435 nm (UV)
190-850 nm (UV-VIS)
190-1100 nm (UV-NIR)
- Compact design: Down to 25x48x16 mm



FREEDOM UV

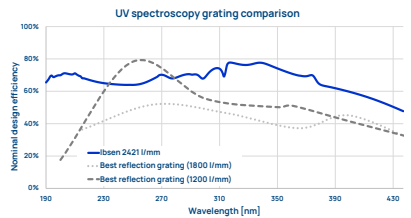

Application example

Example Agriculture, PAT, Pharma

- High Sensitivity
- Low Straylight
- Environmentally stable
- Example product: PEBBLE NIR



Fluorescence Spectroscopy

- Fast data acquisition
- High resolution
- Compact form factor
- Example product: FREEDOM HR



Laser-Induced Breakdown Spectroscopy (LIBS)

- Low trigger jitter of only +/- 10 ns
- 360 ns trigger delay, steps of 200 ns
- High SNR due to high throughput
- Example product: FREEDOM C-UV





THE FUTURE DEPENDS ON OPTICS



EDMUND OPTICS

From Early Ideas to Precision Solutions

Your **One-Stop Shop** for **34,000+** optics from top brands, all supported by fast, reliable delivery and 24/7 technical support. Whether you are building early-stage setups or high-end laser systems, **we deliver products for every stage of research!**

Wherever your research leads, we have the right components—ready to ship, built to perform.

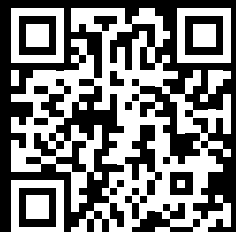

The building blocks
for your lab - from
microscopy to metrology
and beyond!



www.edmundoptics.com



SpitLight
Scientific Lasers

SPITLIGHT EVO



FEATURES

- Up to 100 W average power (1 J @ 100 Hz)
- Versions with improved pulse-to-pulse stability and smooth gaussian beam profile available
- Reliable high-rep-rate performance with up to 1 kHz
- Marketleading diode lifetime
- Excellent size-to-power ratio
- Robust and stable monolithic design
- Easy scalability: EVO I to IV
- System can be injection seeded

INNOLAS
LASER

Stephan Rapp

NANOSECOND YAG LASERS FOR LIBS

FLASHLAMP-PUMPED

DIODE-PUMPED

HIGH POWER



- 1064, 532, 355, 266 nm and 1.57 μm available to **adapt to all materials**
- Compact, portable & rugged for **easy integration**
- High peak power density to **facilitate plasma ignition**
- Repetition rates from Hz to hundred Hz to **optimize acquisition speed**



CONTACT US:
contact@lumibird.com



Peter Bennett



Photronics Industries
International, Inc.

Precision Photon Technology™

Dedicated to nanosecond, picosecond and femtosecond lasers.

RX & SN Pico & Sub-nanosec TEMoo Lasers

RX /SN 1064nm - 10 - 200W | 532nm - 5-200W | 355nm - 3-80W
RX - 7 to 10ps | SN - 100 ps to 5 ns Selectable via Software
Applications: Scribing, PV, Silicon, Glass & Materials Processing

FS Femtosecond Fibre Hybrid TEMoo Lasers

FS 8-200W @ 1030nm | 4-100W @ 515nm | 2-50W @ 343nm
FS-AC <300fs to 5ps | FS-WC <450 fs to 5ps via software
Applications: Glass Cutting, LIPSS Texturing, Transparent Materials

DX TEMoo ns - Intra-cavity Harmonics Lasers

DX 532nm - 2-100W | 1-80W 355nm - Single Cavity
DX-HLP 532nm 30-48W | 355nm - 28-40W | 80ns Single Cavity
Applications: Scribing, Drilling, Silicon Dicing, Silicon Carbide OCF

DP & DPM DPSS Pulsed Pumped 6 to 8 ns Lasers

DP TEMoo 100Hz - 1064nm - 50mJ | 532nm, 355nm & 266nm
DP1K TEMoo 1000Hz - 1064nm - 15mJ | 532nm, 355nm & 266nm
DPM200 MM 100Hz - 1064nm -200mJ | 532nm, 355nm & 266nm
DPM1000 MM 100Hz - 1064nm - 1000mJ | 532nm, 355nm & 266nm
Applications: LIBS, Medicine, Annealing, Sattelite Tracking, LIDAR

DM1 & DM2 ns - Intra-cavity Harmonics Lasers

527nm - 20 to 100mJ | 532nm - 60 to 200W - Single Cavity
351nm - 20 30mJ & 100W - Single Cavity
DM2 - Dual Cavity - Dedicated Compact Laser Head and PSU
Applications: Water-Jet, Annealing, LTP, Ti:SA Pumping & Imaging

photonix.com

Contact us for customisation of any standard laser.



Photronics Industries
International, Inc.

Nano, Sub-Nano, Pico & Femtosecond Solid State Industrial Lasers



30,000+
Lasers Installed

>300
Staff

In 6 Countries



11
Standard
Model Ranges



30+
Patents



>8000
m² Manufacturing



>4,000
m² Clean Rooms



**Pioneering
Intra-Cavity
Harmonic Lasers**



6
Worldwide
Service Centres



photonix.com

Manufacturer of Advance Diode Laser Technology

Monocrom is a Spanish manufacturer founded in 1993, specialized in high-performance laser systems. The company provides innovative, custom photonics solutions globally, serving demanding applications in the industrial, medical, defense, and scientific research sectors.



Our products

- Low Power Diode Laser
- High Power Diode Lasers
- Diode Pumped Solid State Lasers
- Gain Modules
- Laser Electronics

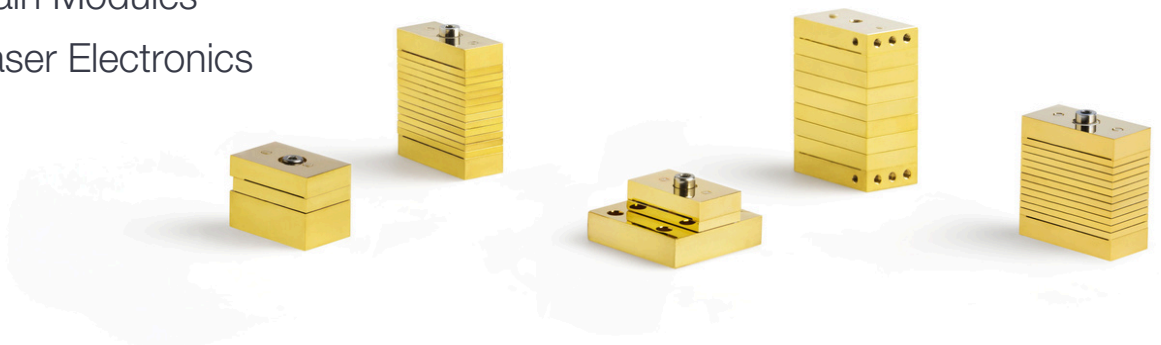

Litron manufacture one of the most comprehensive range of lasers for LIBS – both lamp-pumped and fully DPSS. However, Litron offers more than just a set of off-the-shelf lasers.

The high degree of modularity in the design of Litron’s lasers yields a platform ideally suited to bespoke systems. Combined with our range of resonator types Litron has the flexibility to provide the laser best suited to your application.

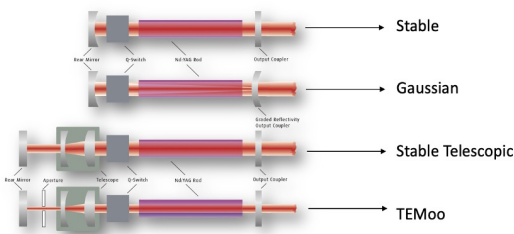

All our product series offer a range of resonator designs. The Gaussian GRM resonator design can be a good choice for LIBS applications due to its low divergence. The TEM₀₀ laser resonator can also be used to give a smaller focused spot size when required. If you are interested in resonator type and why it is important visit our [website](#) to read our technical notes.

Nano Series – an extensive range of ultra compact and rugged, high-performance lamp pumped lasers. 1064nm up to 340mJ and up to 100Hz.



TRLi Series – flexible, modular, high energy, all resonator options and harmonics. 1064nm lamp pumped up to 850mJ and up to 200Hz. Fully DPSS up to 360mJ and up to 300Hz.

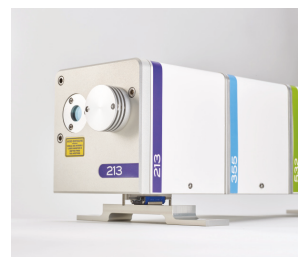

Nano DPSS – fully sealed head with free standing PSU and separate chiller.

- ultra compact
- guaranteed stability
- lowest cost of ownership

1064nm up to 130mJ and up to 300Hz.

Abstracts

Talks

NORDIC
LIBS
2026

Laser Induced Breakdown Spectroscopy: from on-flight applications to ultra trace analysis in lab with NELIBS

A. De Giacomo ^{a, b, c, d, *}, M. Dell'Aglio ^{b, c}, R. Gaudiuso ^{a, c}, A. Taleb ^a, M. Vinic ^a

a Department of Chemistry, University of Bari, Italy

b Institute of Photonics and Nanotechnologies, CNR-IFN, Italy

c Department of Physics and Applied Physics, University of Massachusetts, Lowell, USA

d CSGI - Center for Colloid and Surface Science, Florence, Italy

*Email: alessandro.degiacomo@uniba.it

Laser-Despite the numerous significant applications of Laser-Induced Breakdown Spectroscopy (LIBS) demonstrated over the past few decades, the technique continues to face challenges in achieving broad recognition as a robust analytical tool within the analytical chemistry community. This limited acceptance is primarily attributed to the fact that optimal exploitation of LIBS requires a solid theoretical framework and a comprehensive understanding of the fundamental physical phenomena governing plasma formation and the resulting emission spectra. Paradoxically, these same complexities position LIBS as a uniquely powerful technique, capable of advancing novel analytical approaches. Its inherent features—such as instrument robustness, rapid acquisition times, and the potential for self-calibration—make LIBS particularly suited for cutting-edge applications. This lecture will elucidate the link between the fundamental physics of laser-induced plasma and advanced LIBS methodologies. Particular emphasis will be placed on self-calibrating strategies (including the coupling of self-instrumental and calibration free methodologies) for extraterrestrial exploration, in-flight LIBS techniques for drone-mounted platforms as well as ultra-trace elemental analysis and integrated sensing approaches enabled by Nanoparticle-Enhanced Laser Induced Breakdown Spectroscopy (NELIBS).

LIBS analyses for industrial applications – an overview of developments from 2019-2026

R. Noll ^{a, *}, J. Makowe, V. Moerkens, M. Dargel

a Laser Analytical Systems & Automation GmbH (LSA), Gewerbepark Brand 78, 52078 Aachen, Germany

*Email: reinhard.noll@lsa-systems.de

An overview of the development and implementation activities for industrial applications of LIBS for the period 2019 to 2026 is provided. The materials measured range from metals – aluminium, steel, lead – to non-metals such as coal, salts, ores, minerals, refractory materials, construction waste, rubber and electronic circuit boards. Particular emphasis is placed on the concept of dynamically deflected measurement laser beams and moving measurement objects, which enables automated analysis of individual items transported on conveyor belts. The current status of an industrial LIBS implementation for sorting mixtures of refractory materials is presented.

Smart rubber extrusion: Using an “Inline”-LIBS system as quality-relevant data input for an AI-based process control

B. Klie ^{a, *}, U. Giese ^a, S. Schwabe ^b, M. Dagher ^b, H. Wackerbarth ^b

a Deutsches Institut für Kautschuktechnologie e.V., Eupenerstr. 33, 30519 Hannover, Germany

b Institut für Nanophotonik Göttingen e.V., Hans-Adolf-Krebs-Weg 1, 37077 Göttingen, Germany

*Email: Benjamin.Klie@DIKautschuk.de

The aim of this work is to demonstrate an approach for the digitalization of an extrusion line that combines the use of innovative measuring methods for “inline” process monitoring and algorithms from the field of artificial intelligence (AI) for process control.

To measure quality-relevant data for evaluation of the mixing homogeneity within the extrudate a mobile, two-color double-pulse LIBS system is developed, specially tailored to the demands of “inline” applications. Consequently, a double pulse LIBS system in the collinear geometry with two different wavelengths was developed. For this, two Nd:YAG lasers (Q-smart 450, Lumibird) with a repetition rate of 20 Hz and with 5 ns pulse duration are used. The first laser operates at a wavelength of 266 nm (33.7 ± 1.5 mJ), because UV wavelengths are expected to increase the amount of ablated sample material. The second laser operates at its fundamental wavelength (1064 nm, 154.6 ± 1.7 mJ), as the higher pulse energy leads to an increased plasma temperature. The LIBS system is capable of measuring geometrically complex, “non-flat” extrudates. Furthermore, it incorporates an additional scanning axis perpendicular to the conveyor direction, enabling measurements across the product cross-section and compensation for sample drift on the conveyor. First results focus on zinc (Zn(I) @ 334.4 nm) as an analyte, serving as a marker for the activator in the vulcanization system.

References

¹ ASCHEMANN, A.; KLIE, B.; SCHNEIDER, P.; GIESE, U. et al.: “Smart Rubber Extrusion Line Combining Multiple Sensor Techniques for AI-Based Process Control”, *Advanced Engineering Materials*, 2024., DOI: 10.1002/adem.202401316.

² KLIE, B.; SCHWABE, S.; LENTH, C.; GIESE, U.; WACKERBARTH, H.: „ Conversion of an industrial LIBS system to double-pulse operation to improve sulphur detection in rubber-based parts”, *Spectrochimica Acta Part B: Atomic Spectroscopy*, Volume 215, May 2024, 106923 <https://doi.org/10.1016/j.sab.2024.106923>.

Industrial LIBS Based Sorting of Post-Consumer Wrought Aluminium Alloys for Automotive Applications

Md A. Akram ^{a, *}, Ragnar Holthe ^a, Geir Ringen ^a

a Department of Manufacturing and Civil Engineering, Norwegian University of Science and Technology, Technoligivegen 22,2815, Gjøvik, Norway

*Email: md.a.akram@ntnu.no

Recycling wrought aluminium alloys is essential for reducing energy consumption and greenhouse gas emissions in the automotive manufacturing sector. However, post-consumer aluminium scrap streams are highly heterogeneous and often contaminated, which frequently leads to downcycling and limits their reuse in high-value applications. This study evaluates the industrial-scale implementation of Laser-Induced Breakdown Spectroscopy (LIBS) for the automated sorting of 5xxx, 6xxx, and 7xxx series aluminium alloys under industrial conditions, including painted surfaces. Process scrap was used to measure sorting accuracy, and post-consumer scrap was sorted and then melted for chemical verification using Optical Emission Spectrometry (OES). The results demonstrate high classification accuracy for clean process scrap (approximately 92%), with reduced performance for painted (approximately 69%) materials. Melt composition analysis confirms that 6xxx series alloys consistently met specification requirements, while compliance for 5xxx series alloys was dependent on achieving critical magnesium concentration thresholds. In contrast, effective enrichment of 7xxx series alloys remained challenging due to limited material inflow and systematic underestimation of zinc content. The findings indicate that LIBS is a viable and scalable technology for enabling closed-loop recycling of high-value aluminium alloys, thereby supporting circular economy principles and sustainability objectives in the automotive industry.

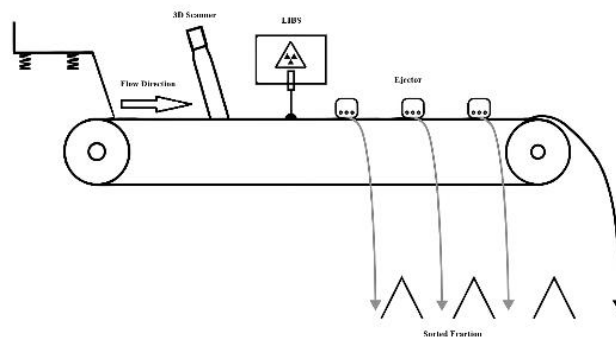

Figure 1. LIBS flow diagram adopted from Steinert LIBS.¹

References

¹ STEINERT Global: STEINERT LSS LIBS Sorting System. <https://steinertglobal.com/sorting-systems/sensor-sorting/lib-s-sorting-systems/steinert-lss-lib/>. Accessed: 2025-12-31 (2025).

Lightigo s.r.o LIBS solutions, Challenges and emerging Applications in Environmental and Industrial systems

L.K. Tinoco Navarro ^{a, *}

a Lightigo s.r.o, Czech Republic

*Email: tinoco@lightigo.com

Lightigo s.r.o. is a Czech deep-tech company founded in 2019, affiliated with the Laboratory of Laser Spectroscopy at CEITEC BUT, specialising in the development and production of advanced LIBS instrumentation for research and industry.

Our instrument portfolio spans laboratory and industrial deployment. The **FireFly** and **DragonFly** platforms serve as high-performance laboratory solutions enabling precision multi-elemental analysis and advanced chemical imaging. For industrial and field settings, the compact **MiniFly** module delivers robust elemental screening directly on the production floor or in harsh environments. All platforms are supported by the **SyncRay** digital pulse generator, enabling nanosecond-precision synchronisation across complex measurement setups.

This contribution highlights emerging LIBS applications where our instrumentation demonstrates unique value. In environmental monitoring, LIBS enables rapid heavy metal screening in solid matrices. In industrial systems, key use cases include lithium battery material analysis, in-line process monitoring, and material sorting. In the life sciences, correlative imaging of clinical tissue samples. Beyond terrestrial applications, LIBS is uniquely suited for the analysis of geological samples and extraterrestrial bodies: its non-contact, vacuum-compatible operation makes it an ideal tool for planetary surveys and in-situ resource utilisation.

We further discuss machine learning integration for calibration transfer, spectral classification, and high-throughput data processing across these diverse domains.

Lightigo welcomes collaboration with Nordic research groups and industrial partners to co-develop application-specific solutions and push LIBS towards new frontiers.

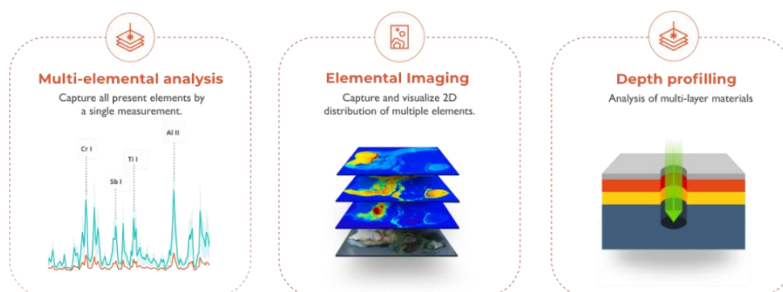

Figure 1. Lightigo s.r.o. solutions Key capabilities.

Foss Analytical A/S **(Elemental abundance analysis for agricultural samples using Laser Induced Breakdown Spectroscopy – Adopting LIBS for commercial laboratories)**

D. Adén

FOSS Analytical A/S, Nils Foss Allé 1, 3400 Hillerød, Denmark

www.fossanalytics.com

Email: dae@foss.dk

Laser Induced Breakdown Spectroscopy (LIBS) is considered a promising new alternative for elemental abundance analysis of agricultural samples, such as forage, soil, and plant leaf tissue, which are crucial for the agriculture-food industry. Present methods, e.g., ICP-OES, are time consuming, cumbersome, and require the use of hazardous acids for sample preparation. LIBS has had difficulties gaining traction within the analytical community due to large sampling uncertainties, and strong sample matrix effects. We present a new method/procedure for carrying out LIBS, which is fully automatic and measures 60 samples an hour, that mitigate said restraints. By using a high-frequency, low pulse energy, setup combined with auto-focus based on plasma emission, sample spectroscopic reproducibility at a few per cent is achieved. Furthermore, by exposing plant-based samples to a thermal decomposition prior to LIBS, sample matrix effects are reduced significantly, allowing for the construction of robust multivariate models for macro nutrients (Ca, K, Mg, Na, S, P) and micronutrients (Fe, Al, Cu, Zn, Mn, B). Said models are calibrated and validated using thousands of samples, as opposed to the typical handful of samples when prediction modelling for LIBS is explored. We conclude that LIBS has reached the point in time when it's ready to be adopted by the agriculture-food industry on a large scale, since it's fast, cheap, and environmentally friendly, and that LIBS will play a major role as the world moves towards a more sustainable food production, carbon footprint reduction, and an era where more consumers require healthy food.

FOSS

InnoLas Laser GmbH

S. Rapp

InnoLas Laser GmbH, Justus-von-Liebig-Ring 8, 82152 Krailling, Germany
www.innolas-laser.com

Email: Stephan.Rapp@innolas-laser.com

InnoLas Laser develops and manufactures nanosecond high pulse energy laser sources of the highest quality for scientific and industrial applications. We not only stand for excellent German workmanship, but also for customer proximity and first-class service. Our success is largely based on the expertise and teamwork of our employees, who constantly deliver top performance. For us, a pleasant working atmosphere is an important prerequisite for such successful development. We look forward to further sustainable growth of our company, many satisfied new and existing customers, new challenges and, above all, to further improving our products for the benefit of our customers!



LUMIBIRD

P. Bennett

Lumibird, 2 Rue Paul Sabatier, 22300 Lannion, France
www.lumibird.com

Email: pbennett@lumibird.com

LUMIBIRD is one of the world's leading specialists in lasers. With over 50 years of experience and expertise in 3 key technologies - solid-state lasers, laser diodes and fiber lasers - the group (formerly Quantel-Keopsys) designs and manufactures high performance lasers for the industrial, scientific, space, defense and medical markets.

Listed on the stock exchange, the group is headquartered in France and is present on several continents through its 12 production and R&D sites and its sales and support offices. LUMIBIRD has more than 1000 employees.

LUMIBIRD offers a wide range of pulsed solid-state lasers for LIBS applications.

Whether flash lamp or diode-pumped, our nanosecond Nd:YAG lasers are perfectly suited to the specific needs of LIBS applications:

- Various wavelengths available (1064, 532, 355, 266 nm and 1.57 μm) to adapt to all materials
- Compact, portable and rugged packages for easy integration in LIBS equipment
- High peak power density for facilitating plasma ignition: good focusing (GRM cavities), short pulse duration (few ns) and high energy (from mJ to J)
- Repetition rates from Hz to hundreds of Hz to optimize speed of acquisition

Viron, Shrike, Ultra, Q-smart, Merion... you are sure to find in our range the laser that works best for your LIBS application.

All our models are described on our website, but also on our virtual booth. Take a look and enjoy your visit!



MONTFORT Laser GmbH & Co KG

J. Fellingner

Montfort Laser GmbH & Co KG, Im Holderlob 6a, 6840 Götzis, Austria
www.montfortlaser.com

Email: JF@montfortlaser.com

MONTFORT Laser develops and manufactures extremely compact pulsed DPSSL lasers that deliver performance unmatched at their form factor, with excellent long-term stability. The M-NANO series of compact, all-in-one Nd:YAG nanosecond lasers generates pulse energies exceeding 200 mJ from a palm-sized laser head, serving applications such as LIBS, PIV, LIF, photoacoustics, and LIDT testing. Our core expertise lies in making high-energy nanosecond lasers exceptionally compact, robust, and lightweight relative to their energy and peak power output.

As an example, the M-NANO model PR193 — weighing approximately 2 kg — is a fully self-contained nanosecond laser: no external boxes, no chiller, no water cooling. Simply connect 24 VDC power (a laptop-style supply is included), provide your commands and triggers, and the system is ready to pulse. The entire M-NANO series is optimized for low power consumption, high beam quality, and long operational lifetime.

MONTFORT Laser also offers precision and high laser damage IBS coatings through its NANE0 brand.



Quantum Light Instruments Ltd.

P. Ziedelis

Quantum Light Instruments Ltd., Mokslininkų g. 6A, Vilnius, 08412 Vilniaus m. sav., Lithuania
www.qlinstruments.com

Email: povilas.z@qlinstruments.com

Quantum Light Instruments: Precision Laser Solutions from Lithuania

Founded in 2014 in Vilnius, Lithuania, **Quantum Light Instruments, Ltd. (QLI)** is a manufacturer of high-performance Diode-Pumped Solid-State (DPSS) nanosecond pulsed lasers. Our systems are engineered to meet the rigorous demands of scientific research, industrial integration, defense, and medical applications.

Advanced Technology and Versatility

We specialize in both actively and passively Q-switched lasers, utilizing Nd:YAG and Nd:YLF crystals powered by advanced end-pumping technology.

Our systems deliver impressive performance, with pulse energies reaching up to 200 mJ and repetition rates ranging from 1–200 Hz to 1–100 kHz, depending on the specific model.

The "Water-Free" Advantage

One of Quantum Light Instruments' standout innovations is our fully air-cooled, "water-free" technology. By eliminating the need for external chillers, bulky power supplies, or complex water-cooling loops, we provide compact, single-box systems that are easy to integrate and maintain, even in space-constrained environments.

Customization and Precision

We offer a comprehensive suite of accessories, including harmonic generators (up to the 5th harmonic with up to three output ports), OPOs, Raman shifters, attenuators, energy monitors, and fiber-coupling modules. Our harmonic generation capabilities extend the laser output into the deep-UV spectrum, reaching 211–213 nm.

Innovation Through Collaboration

At Quantum Light Instruments, we believe that true innovation begins with listening. Every customer re-request is an opportunity to refine our technology. Whether you require a standard compact laser for laboratory research or a custom high-energy system for industrial use, our team is dedicated to tailoring solutions that fit your exact requirements.



Edmund Optics

L. Favé

Edmund Optics GmbH, Isaac-Fulda-Allee 5, 55124 Mainz, Germany
www.edmundoptics.eu

Email: LeaF@edmundoptics.co.uk

About Edmund Optics

With over 80 years of experience, Edmund Optics® is a trusted provider of high-quality optical components and solutions, serving industries like Life Sciences, Biomedical, Industrial Inspection, Semiconductor, and R&D. The company employs 1,300+ people across 19 global locations and continues to grow.

As a leading optics and photonics company, Edmund Optics provides two specialized solutions: a robust **Marketplace** with 34,000+ off-the-shelf products and **Advanced Manufacturing**, which focuses on custom and volume production of precision optical and imaging components.

Edmund Optics' **Marketplace** is a one-stop shop for over 34,000 in-stock products from in-house manufacturing and 40+ top-tier brands, covering the entire beam path with fast, easy purchasing. For tailored solutions, **Advanced Manufacturing** offers custom design, first-article production, and scalable manufacturing – supported by four global design centers and nine specialized factories producing over 2 million components and 175,000+ assemblies annually.

Learn more at www.edmundoptics.com.



Photonics Industries Europe, BV

H. Taylor

Photonics Industries Europe BV, Mercurion 26, 6903 PZ Zevenaar, Netherlands
www.photonix.com

Email: htaylor@photonix.com

Photonics Industries specialises in technology leading femtosecond, picosecond, sub-nanosecond and nanosecond solid-state lasers designed for high-precision industrial material processing applications. PI is a dedicated OEM laser source design and manufacturing specialist supplying more than 90% of our output to system integrators and machine builders.

We are the pioneers of intra-cavity harmonics lasers with exceptional Green and Ultraviolet harmonic conversion efficiency and exceptional M2 <1.1 beam quality.

Our range includes six key series to meet all the requirements of current and future laser processing applications. This includes options in the IR, visible, UV and deep UV.

Femtosecond	TEMoo	8 to 200W
Picosecond	TEMoo	10 to 200W
Sub-Nanosecond	TEMoo	10 to 250W
Nanosecond	TEMoo	5 to 100W
Nanosecond	MM	20 to 400W
Pulsed Nanosecond	TEMoo	1 to 20+W

We design and build ultra-compact All-In-One (AOI) monolithic laser heads engineered for electrical and optical efficiency and long-term power stability. Using fully sealed-in-factory laser heads with advanced onboard monitoring and tuning, our lasers are intended for long-term 24/7 operation.



Ibsen Photonics A/S

R. B. Sterobo

Ibsen Photonics A/S, Ryttermarken 17, 3520 Farum, Denmark
www.ibsen.com

Email: Rasmus.B.Sterobo@ibsen.com

At Ibsen Photonics, we design and manufacture the world's best gratings and spectrometers. Our compact, high-performance spectrometers boast minimal unit-to-unit performance variation and robust environmental stability, leading to reduced implementation costs and eliminating the need for field calibration and re-calibration. We serve as a strong long-term strategic partner for industrial companies, to help our customers increase their sales and win market share.



LIBS for the Analysis of Fusion-Relevant Plasma-Facing Components

P. Veis ^{a, *}, S. Atikukke ^a, S. J. Shetty ^a, M. Veis ^a, M. Mohan ^a

a Faculty of Math., Physics and Informatics, Comenius Univ., Mlynská dol. F2, 84248 Bratislava, Slovakia

*Email: pavel.veis@fmph.uniba.sk

In the last decade, Laser-Induced Breakdown Spectroscopy (LIBS) has become an increasingly important diagnostic technique for the analysis of plasma-facing components (PFCs) in fusion devices, where materials are exposed to extreme thermal and particle fluxes. Tungsten is widely used as a plasma-facing material due to its high melting point, low sputtering yield, and favourable thermomechanical properties. In addition, boron-based coatings and boronization are commonly applied in fusion devices to reduce oxygen impurities and improve plasma performance. However, plasma-wall interactions result in material erosion, redeposition, impurity accumulation, and retention of hydrogen isotopes, creating the need for reliable analytical methods capable of depth-resolved compositional analysis.^{1,2,3}

In this contribution, recent developments in LIBS diagnostics of tungsten and boron-containing plasma-facing materials are presented, with particular emphasis on depth profiling and quantitative analysis. LIBS offers several advantages for fusion applications, including rapid multi-element detection, minimal sample preparation, and the possibility of in situ measurements under low-pressure conditions relevant to fusion environments. The study explores different experimental approaches aimed at improving spectral quality, analytical sensitivity, and depth resolution for the characterization of fusion-relevant materials.^{4,5} The presented results demonstrate the strong potential of LIBS for the investigation of plasma-facing components, including the analysis of deposited layers, impurity migration, mixed material formation, and hydrogen isotope retention. The obtained findings contribute to the further development of LIBS as a versatile and promising diagnostic tool for plasma-wall interaction studies and materials research in present and future fusion devices.

Acknowledgement

The authors acknowledge the Scientific Grant Agency of the Slovak Republic (VEGA-1/0815/25 and 2/0120/25), the Slovak Research and Development Agency (APVV-22-0548 and APVV-23-0281) for financial support.

References

- ¹ G. S. Maurya et al., *J. Nucl. Mater.* 2020, 541, 152417.
- ² P. Veis et al., *Nucl. Mater. Energy* 2020, 25, 100809.
- ³ H. Wu, R. Yi, S. Brezinsek et al., *Nucl. Mater. Energy* 2025, 45, 102018.
- ⁴ J. Ristkok, P. Veis, S. Atikukke et al., *Nucl. Mater. Energy* 2025, 44, 101968.
- ⁵ S. Almaviva, L. Baiamonte, M. Pistilli et al., *J. Nucl. Eng.* 2025, 6, 22.

Automated ML-based tool for spectra reconstruction, processing and visualization for LIBS data obtained in LIBS @JET experiment

P. Gasior^{a, *}, D. Sokulski^a, S. Almaviva^b, J. Karhunen^c, J. Linkonen^c, S. Soni^d, S. Atikukke^d, P. Veis^d, S. Shetty^d, M. Veis^d, J. Butikova^e, S. Brezinsek^f, R. YI^f, R. Rayaprolu^f, G. Sergienko^f, E. Wüst^f, T. Dittmar^f, Ch. Kawan^f, M. Sackers^f, I. Jezu^g, I. Jogi^h, J. Ristkok^h, P. Paris^h, C. Porosnicuⁱ, A. Widdowson^j, N. Jones^j, and UKAEA RACE Team^l

a IPPLM Institute of Plasma Physics and Laser Microfusion, Warsaw, Poland

b ENEA, Frascati research center, Frascati, Italy

c VTT, P.O. Box 1000, Espoo 02044 VTT, Finland

d Department of Experimental Physics, FMPI, Comenius Univ., Bratislava, Slovakia

e Institute of Solid State Physics, University of Latvia, Riga, Latvia

f Forschungszentrum Jülich, IFN-1 Plasma Physics, Jülich, Germany

g United Kingdom Atomic Energy Authority, Culham Campus, Abingdon, UK

h Institute of Physics, University of Tartu, Tartu, Estonia

i INFLPR 409, Magurele, Jud Ilfov, Bucharest, Romania

*Email: pawel.gasior@ifpilm.pl

After the groundbreaking DTE-3 campaign at JET tokamak, which brought a new world energy record in thermonuclear energy output, LIBS @JET experiment has been launched to investigate in-vessel fuel retention in plasma-facing components. A laser head with beam delivery and light collection system has been mounted on a remotely controlled MASCOT manipulator, which allowed for obtaining spectra from over 800 positions including beryllium first wall and tungsten divertor. As the irradiation source a Monfort Nd:YAG tabletop laser module has been deployed which provided 800 ps, 10 mJ pulses at 1064 nm wavelength. With the use of a fiber bundle, the light induced by the laser pulses was transmitted to Aryelle, Avantes and Littrow spectrometers, the first two dedicated to measure the broad spectral range with medium and low resolution, the third one to distinguish lines attributed to hydrogen isotopes in the narrow wavelength range, which required high spectral resolution.

The measurements achieved a spatial resolution of 130 mm and depth resolution 180 nm, which brought enormous amounts of data, only the Aryelle spectra exceeded the volume of 1 TB. Since such large amounts of spectra require automated analysis a set of algorithms has been developed to convert, process and visualize the data.

Conversion saves the data frames with spectra to hdf format, which reduces the volume and speeds up further processing. After that spectra are dimensionally reduced with automated spectral range selection and autoencoders, which further significantly decreases their size from ~40 k to a few hundred features. Two-step anomaly detection is applied: before reconstruction (based on detection of anomalous spectral features) and after reconstruction (based on detection of anomalous reconstruction errors).

The tool offers visualization of spectral depth profiles for selected lines and sets corresponding to chosen elements for both processed and unprocessed spectra for any experimental location and estimates the reconstruction accuracy.

Demonstration of LIBS as a tritium monitoring tool in fusion reactors

A. Hakola ^{a, *}, J. Likonen ^a, J. Karhunen ^a, S. Almagia ^b, I. Jecu ^c, A. Widdowson ^c, S. Brezinsek ^d, the EUROfusion WPPWIE LIBS Team and UKAEA Race Team

a VTT Technical Research Centre of Finland Ltd., Espoo, Finland

b ENEA, Diagnostics and Metrology Laboratory, Frascati, Italy

c United Kingdom Atomic Energy Authority, Culham Campus, Abingdon, UK

d Forschungszentrum Jülich GmbH, IFN-1 Plasma Physics, Jülich, Germany

*Email: antti.hakola@vtt.fi

We discuss here recent advances obtained in developing LIBS as a monitoring tool for the radioactive tritium in future fusion reactors. We focus on the results obtained and lessons learnt from a measurement campaign with a tailor-made LIBS system (Figure 1) at the JET tokamak after completing a series of experimental operations including a unique phase with deuterium-tritium plasmas; such experiments have been extremely rare during the last decades and thus provide first-hand information on how tritium would be retained on the inner wall structures of a tokamak-type fusion device.

LIBS measurements have reproduced deposition patterns of eroded wall materials in different regions of the tokamak and showed that tritium is predominantly retained via co-deposition with other elements.¹ The results also show little tritium being left on the vessel following cleaning operations in the tokamak, giving confidence that interventions into a fusion reactor and maintenance operations can be done in a safe manner. Ongoing activities include quantification of the tritium amounts, challenged by the presence of other hydrogen isotopes on the wall components. We also report on comparative studies in laboratory conditions and outline the European research strategy for using LIBS in devices relevant for the operations in ITER.

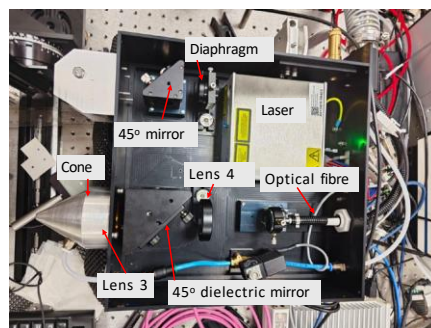

Figure 1. Schematic illustration of the LIBS system applied on JET.

References

¹Likonen, J *et al.*, Nuclear Materials and Energy **45** (2025) 102021.

Quantification of impurities in different oxides via calibration-free LIBS

C. Gerhard ^{a, *}, J. Hermann ^b

^a University of Applied Sciences and Arts, 37085 Göttingen, Germany

^b Aix-Marseille University, CNRS, LP3, 13288 Marseille, France

*Email: christoph.gerhard@hawk.de

Technical oxide materials such as glasses or ceramics may feature quite notable differences in chemical stability and resistance. Hence, classical finishing methods such as polishing may lead to significant variations in surface contamination by operating materials used for surface treatment. Such variations were quantified in this work where sensitivity-improved calibration free LIBS was used for quantifying both the oxide bulk material composition and the fraction of foreign matter and impurities. In the present contribution, the used LIBS algorithm, which is based on iterative deduction of plasma parameters such as electron density, temperature, and chemical composition from the comparison of measured and computed spectra^{1,2} is introduced. Moreover, analysis results obtained on lead silicate³ and barium silicate materials are presented and discussed. The obtained data reveal that surface contamination correlates well with the chemical resistance and stability of the investigated oxides, thus providing valuable insights into interactions at oxide materials surfaces.

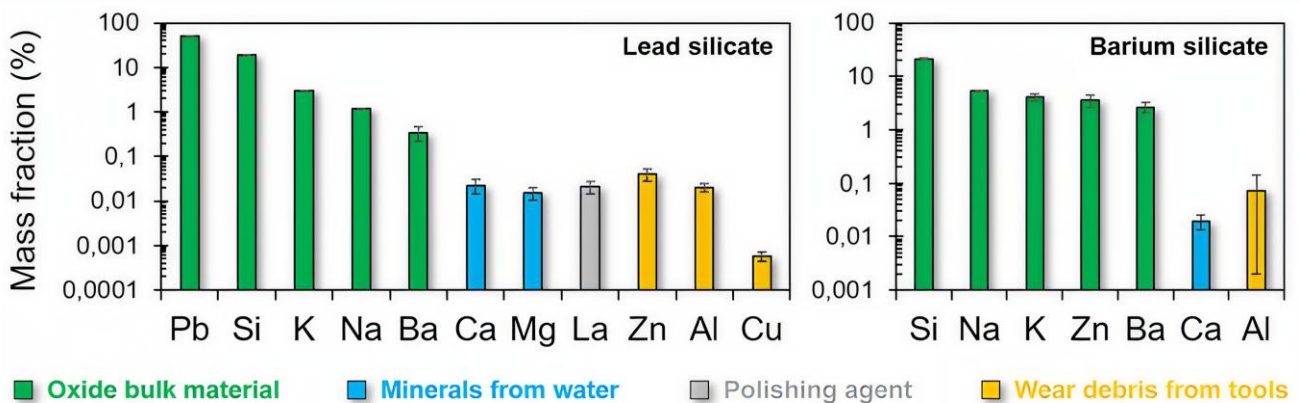

Figure 1. Composition of different polished oxide surfaces as determined via calibration-free LIBS.

References

- ¹ C. Gerhard, J. Hermann, L. Mercadier et al.: *Quantitative analyses of glass via laser-induced breakdown spectroscopy in argon*, Spectrochimica Acta Part B 101 (2014) 32-45.
- ² J. Hermann, C. Gerhard, M. Burger et al.: *Progress in calibration-free laser-induced breakdown spectroscopy*, Spectrochimica Acta Part B 200 (2023) 106595.
- ³ C. Gerhard, A. Taleb, F. Pelascini, J. Hermann: *Quantification of surface contamination on optical glass via sensitivity-improved calibration-free laser-induced breakdown spectroscopy*, Applied Surface Science 537 (2021) 147984.

Influence of Structured Laser Beam Profiles on Ablation Dynamics and Analytical Performance in LIA-QMS

S. Soni ^{a, *}, U. Von Toussaint ^a, M. Mayer ^a, T. Schwarz-Selinger ^a

a Max Planck Institute for Plasma Physics, Boltzmannstrasse 2, Garching, D-85748, Germany

*Email: Shweta.soni@ipp.mpg.de

Femtosecond laser-induced ablation quadrupole mass spectrometry (fs-LIA-QMS) enables precise depth-resolved analysis of deuterium (D) retention in various materials including tungsten (W), a key plasma-facing material in fusion devices. Laser-induced ablation is highly sensitive to the spatial distribution of laser energy on the sample surface, affecting material removal, plume dynamics, and the analytical signal. In this study, we investigate the effects of structured beam profiles on the ablation behavior and detection sensitivity. We validated the LIA-QMS setup using tungsten samples consisting of a three-layer structure. A deuterium-containing tungsten layer was sandwiched between a tungsten top layer and a bulk tungsten substrate. The thickness of the deuterated layer was varied between 50 nm, 100 nm, and 200 nm. A 400 fs laser beam with Gaussian, flat-top, annular, and annular-core intensity distributions using an airy beam-shaping element were used. Motorized axial movement of the focusing lens (≈ 2 mm relative to its 163 mm focal length) systematically modified the spatial intensity distribution along its focal axis at a constant fluence.

Fs-LIA-QMS achieved ~ 8 – 17 nm ablation rate per pulse via pulse-by-pulse material removal and quantitative D_2 detection using a QMS. Post-measurement confocal microscopy revealed distinct differences in crater morphology: Gaussian beams produced ~ 13 μm diameter craters, flat-top beams ~ 28 μm , and annular beams produced donut-shaped craters with varying diameters at different focal positions. Annular beam profiles produced wider but shallower craters (ablation rate ~ 8 nm/pulse) compared to Gaussian beams (~ 17 nm/pulse), while flat-top beams improved shot-to-shot signal stability. QMS signals reflected these morphological differences. Gaussian beams produced sharper and shorter D_2 signals, whereas some annular beams have asymmetries resulting in double-peaked D_2 signals leading to analytic complexities. Depth profiles from fs-LIA-QMS were compared to profiles obtained by Nuclear Reaction Analysis using incident ^3He ions at MeV energies. Preliminary results indicate that structured beam profiles significantly alter the crater morphology, influence plume formation, and produce measurable differences in signal stability and ion yield. These findings demonstrate the potential of beam profile engineering to optimize laser-matter interactions and enhance analytical performance in LIA-QMS.

LIBS Bioimaging: A Comprehensive Overview from Environmental Monitoring to Plant Growth Beyond Earth

J. Kaiser ^{a, b, *}, L. Čechová ^a, T. Vozár ^a, J. Buday ^{a, b}, P. Pořízka ^{a, b}

a Central European Institute of Technology, Brno University of Technology, Purkyňova 123, 612 00 Brno, Czech Republic

b Faculty of Mechanical Engineering, Brno University of Technology, Technická 2896, 616 69, Brno, Czech Republic

*Email: Jozef.Kaiser@ceitec.vutbr.cz

Laser-induced Breakdown Spectroscopy (LIBS) is a powerful analytical tool for spatially resolved multi-elemental characterization of biological and environmental samples. LIBS enables rapid, in-situ elemental analysis with minimal sample preparation and simultaneous multi-element detection. These features position LIBS as a uniquely versatile technique bridging environmental monitoring, plant science, and space exploration applications.

This work provides a comprehensive overview of LIBS bioimaging from the detection of emerging contaminants in plant tissue to the monitoring of plant growth in extraterrestrial substrates, known as regolith. LIBS bioimaging has become an important tool for visualizing the distribution of macro- and micronutrients, toxic elements, and nanoparticles at micrometer spatial resolution. Elemental mapping of roots, leaves, and stems provides insights into nutrient transport, mechanisms of phytotoxicity, and plant physiological responses, enabling an improved understanding of plant–environment interactions.¹ Advances in machine-learning-assisted calibration continue to improve quantitative accuracy and imaging performance in complex biological matrices.²

Extending beyond terrestrial applications, LIBS can play a crucial role in planetary science and astrobiology, where its ability to perform remote elemental analysis aligns with the constraints of extraterrestrial missions. LIBS bioimaging supports studies of regolith–plant interactions, nutrient availability, and adaptive mechanisms required for sustainable plant cultivation in lunar environments.

Acknowledgement

The authors gratefully acknowledge the support of grant no. FSI-S-26-9044 (Brno University of Technology).

References

¹ Modlitbová, P., Pořízka, P., and Kaiser, J. *Laser-induced breakdown spectroscopy as a promising tool in the elemental bioimaging of plant tissues*, Trends in Analytical Chemistry, 122, pp. 115729, 2020.

² Čechová, L., Holub, D., Kurka, M., Pouzar, M., Pořízka, P., & Kaiser, J. *Quantitative LIBS imaging of cadmium in plant tissues with matrix-based calibration supported by micro-X-ray fluorescence spectroscopy*. Spectrochimica Acta Part B: Atomic Spectroscopy, 107389, 2026.

Laser-Induced Breakdown Spectroscopy for Soil Characterisation: Status of Aarhus University Research

M. Knadel ^{a, *}

a Dept. of Agroecology, Aarhus University, Denmark

*Email: maria.knadel@agro.au.dk

Soil analysis underpins decisions on fertilisation, carbon accounting and soil health assessment, yet conventional methods remain labour-intensive, costly and difficult to scale. Growing interest in soil health and implementation of the EU Soil Monitoring Law have increased the need for rapid and cost-effective soil monitoring approaches. At the Department of Agroecology, Aarhus University, our work has explored laser-induced breakdown spectroscopy (LIBS) as a rapid, multi-element method for soil characterisation, focusing on phosphorus, soil organic carbon (SOC) and texture. This presentation summarises progress from laboratory feasibility studies to larger-scale and more field-relevant applications. Early Danish studies showed that LIBS can perform comparably to visible–near-infrared spectroscopy (vis–NIRS) for predicting SOC and particle-size fractions, while local calibration “spiking” improved model robustness.¹ Later work focused on phosphorus, demonstrating the potential of LIBS, alone and combined with vis–NIRS and variable-selection methods, for estimating agronomically and environmentally relevant P pools while highlighting matrix effects linked to particle size and phosphorus form.² More recent studies have addressed sample pretreatment,³ pan-European soil spectral libraries,⁴ handheld LIBS,⁵ repeatability and data-fusion strategies.⁴ Results indicate that LIBS can predict SOC and texture across diverse soils and that minimal pretreatment may be sufficient for some applications. Together, the studies indicate that LIBS is moving from proof-of-concept towards operational soil sensing, with potential to support large-scale soil monitoring and precision agriculture.

References

- ¹ Knadel, M., Peng, Y., Gislum, R., Hermansen, C., Greve, M.H. Comparing predictive ability of laser-induced breakdown spectroscopy to visible near infrared spectroscopy for soil property determination. *Biosystems Engineering*, 156, 157-172. 2017
- ² Sanchez, S., Knadel, M., Labouriau, R., Rubæk, G.H., Heckrath. Total phosphorus determination in soils using laser-induced breakdown spectroscopy: evaluating different sources of matrix effects. *Applied Spectroscopy*, 0003702820949560. 2021
- ³ Wangeci, A., D Adén, MH Greve, M Knadel. Effect of sample pretreatment on pelletization and performance of laser-induced breakdown spectroscopy for predicting key soil properties. *Spectrochimica Acta Part B: Atomic Spectroscopy* 206, 106712. 2024
- ⁴ Wangeci, D Adén, T Nikolajsen, MH Greve, M Knadel. Comparing laser-induced breakdown spectroscopy and visible near-infrared spectroscopy for predicting soil properties: A pan-European study. *Geoderma* 444, 116865. 2024
- ⁵ Wangeci, A, M. Knadel, O De Pascale, MH Greve, GS Senesi. Assessing the performance of handheld LIBS for predicting soil organic carbon and texture in European soils. *Journal of Analytical Atomic Spectrometry*. 2024

How Far Can LIBS Imaging Go? A Journey Across Scales

V. Motto-Ros^{a, b, *}

^a ILM, University of Lyon 1, 69100 Villeurbanne, France

^b ABLATOM SAS, 69100 Villeurbanne, France

*Email: vincent.motto-ros@univ-lyon1.fr

Laser-induced breakdown spectroscopy (LIBS) imaging has evolved significantly over the last decade, progressively extending the range of spatial scales accessible to elemental imaging while preserving its core strengths: multi-element capability, sensitivity to light elements, and operation under ambient conditions.^{1,2}

Recent advances in high-repetition-rate laser sources, fast detectors, and optimized scanning strategies have enabled a major increase in acquisition throughput. As a result, LIBS imaging can now cover surfaces reaching several hundreds of square centimeters while maintaining micrometric spatial resolution on the order of 10 μm . Such capabilities are particularly well suited to the investigation of chemically complex and highly heterogeneous samples, as encountered in geosciences, materials science, and industrial environments, where spatial variability plays a central role (c.f. figure 1). In parallel, continued developments in beam shaping, focusing optics, and signal optimization have pushed LIBS imaging toward higher spatial resolution. Lateral resolutions approaching the micrometer scale ($\sim 1 \mu\text{m}$) are now achievable, allowing the investigation of fine microstructures, interfaces, and heterogeneous phases that were previously inaccessible to conventional LIBS imaging.

By bridging high-throughput, large-area mapping and ultra-high spatial resolution through complementary instrumental implementations of LIBS imaging, this presentation illustrates how LIBS imaging has become a scale-transcending technique. This journey across scales highlights how instrumental innovation and analytical ambition jointly define how far LIBS imaging can truly go.

Keywords: μ - LIBS imaging, Multi-scale analysis, High-throughput mapping, Spatial resolution

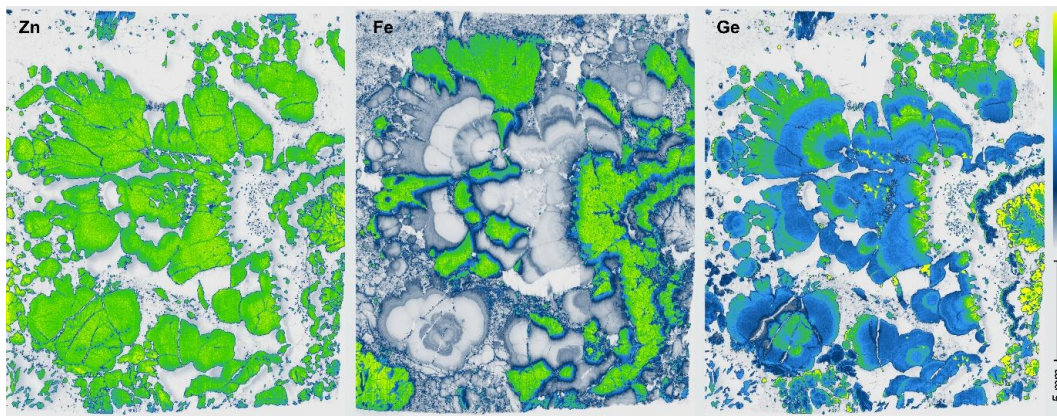

Figure 1. Elemental LIBS images of zinc (Zn), iron (Fe), and germanium (Ge) in sphalerite, revealing distinct chemical zonations.

References

¹ L. Jolivet, M. Leprince, S. Moncayo, L. Sorbier, C.-P. Lienemann and V. Motto-Ros, *Spectrochimica Acta Part B: Atomic Spectroscopy*, 2019, **151**, 41–53.

² V. Gardette, V. Motto-Ros, C. Alvarez-Llamas, L. Sancey, L. Duponchel and B. Busser, *Anal. Chem.*, 2023, **95**, 49–69.

Analysis of single particles for aerosol research and water monitoring

J. Toivonen ^{a, *}, P. Kajovirta, S. Järvinen, J. Keskinen

a Aerosol Physics and Photonics Laboratories, Physics Unit, Tampere University, Tampere, Finland

*Email: juha.toivonen@tuni.fi

Elemental analysis of individual aerosol particles is a powerful tool for monitoring industrial process waters, environmental effluents, and ambient air quality. This work presents advanced methodologies for the analysis of single particles using laser-induced breakdown spectroscopy. By converting liquid samples into monodisperse aerosols and utilizing electrodynamic balance trapping, we eliminate the suppressive effects of the liquid matrix and achieve strong preconcentration of trace elements.¹ This approach has yielded limits of detection as low as 10–60 ppb for transition metals like Ni, Pb, and Zn, utilizing compact lasers having pulse energies below 15 mJ.

Furthermore, we introduce a spectroscopy platform designed for ambient aerosol analysis, enabling in-situ elemental characterization of individual ambient particles.² Utilizing a linear electric quadrupole focusing system and a size amplification aided aerosol charging approach, the platform successfully analyzes submicron particles down to 300 nm, with absolute mass detection limits in the femtogram range (1–100 fg) and achieves a maximum analysis speed of approximately 20 particles per minute. The system's multi-element capability allows for the classification of particles by chemical composition directly from the carrier gas, minimizing artifacts associated with filter-based sampling.

References

¹ S. Järvinen, and J. Toivonen, *Analysis of single mass-regulated particles in precisely controlled trap using laser-induced breakdown spectroscopy*, *Optics Express* **24**, 1314 – 1323 (2016).

² P. Heikkilä, A. Rostedt, J. Toivonen, and J. Keskinen, *Analysis and classification of individual ambient aerosol particles with field-deployable laser-induced breakdown spectroscopy platform*, *Aerosol Science and Technology* **58**, 1063 – 1078 (2024).

Challenges when operating a commercial LIBS instrument in the far UV

K. B. Kinch ^{a, b, *}, M. Styrk-Geisler ^a, D. Adén ^a, K. Nedenskov Jensen ^a

a Foss Analytical, Hillerød, Denmark

b Niels Bohr Institute, University of Copenhagen, Copenhagen, Denmark

*Email: kjki@foss.dk

Foss Analytical released the Micral™ LIBS elemental analyzer¹ in 2024. Micral™ is a commercial LIBS elemental analyzer for agricultural laboratories, measuring 6 macro elements (Ca, Mg, P, K, Na, S) and 6 micro elements (Al, B, Cu, Fe, Mn, Zn), and providing analysis of silage and plant leave samples with a throughput approaching 60 samples per hour with heavy use.

The instrument acquires LIBS spectra at a wavelength range of 178 nm – 427 nm. The choice of the short-wavelength end of this range was driven primarily by a desire to access three sulfur lines² at 180.73 nm, 182.03 nm, and 182.63. Sulfur is, of course, a significant plant nutrient and thus an element of particular significance for this application.

During the instrument development process, the far ultraviolet region below 200 nm posed particular challenges. Mirrors and optical fibers had to be chosen with care in order to show the required stability with long-term use as well as the uniformity across instruments expected from customers. In addition, the very high absorption coefficient of molecular oxygen below 200 nm necessitated a design with an oxygen-free light path, but the requirement of large sample throughput made vacuum impracticable. The solution is continuous purging with pure nitrogen. Making this purging work consistently across many customer sites in different countries and with different levels of user experience, has also required us to overcome significant challenges.

References

¹ <https://www.fossanalytics.com/en/products/micral>.

² Gazeli, O.; Stefas, D.; Couris, S: *Sulfur Detection in Soil by Laser Induced Breakdown Spectroscopy Assisted by Multivariate Analysis*, Materials 2021, 14, 541. <https://doi.org/10.3390/ma14030541>.

Elemental Scientific

M. Szoltysik

Elemental Scientific Instruments Nordics AB, Spannmålgatan 9, 291 32 Kristianstad, Sweden
www.icpms.com

Email: Michael.szoltysik@icpms.com

Elemental Scientific, Inc (ESI) – Global Leaders in Lab Automation

ESI leads in lab automation, sample intro, online monitoring, and laser ablation. Our mass spectrometry technology excels globally, known for top-notch products and custom solutions. From smart autosamplers to FAST apps, we enhance your ICP/ICPMS experiments, boosting speed, precision, and accuracy. Our laser experts (Elemental Scientific Lasers) have decades of experience in laser spectroscopy, providing reliable and high-performing laser ablation and laser-induced breakdown spectroscopy based systems.



LTB Lasertechnik Berlin GmbH (CRM Inhomogeneity – Impact on LIBS Calibration)

S. Merk ^{a, *}, V. Merk ^a, J. Kostrzewa ^b, J. Anyszkiewicz ^b, L. Pfeifer ^b

a LTB Lasertechnik Berlin (www.ltb-berlin.de)

b Łukasiewicz Research Network - Institute of Non-Ferrous Metals

*Email: sven.merk@ltb-berlin.de

Certified reference materials are often designed with certain techniques in mind. Standard laboratory techniques, like diverse ICP-based methods, rely on dissolving a fair amount of material. For such techniques, a certain level of inhomogeneity is acceptable if the typical amount of sampled material includes enough of the sample bulk to average out those inhomogeneities. In LIBS however, due to the small size of typical ablation areas, this has to be overcome by increasing the scan area and thus measurement time, still relying on the not necessarily fulfilled condition that surface homogeneity mirrors in-depth homogeneity.

We present a study based on a set of certified reference materials, that are still under development, where special focus was set on the homogeneity of given samples, having the LIBS calibration in mind. We compare simple calibration results using only certified reference materials. The calibration is performed first using regular off-the-shelf copper CRM samples and second replacing some of them with their more homogenous twins. Furthermore, the homogeneity of the samples was analyzed using LIBS mapping. An improvement of concentration recovery is clearly visible using CRM samples that are optimized for LIBS even for large sampling areas and thus number of averages.



Multimodal imaging for the analysis of stroke and cancer

P. Pořízka ^{a, *}, D. Kočenda ^a, J. Biskupič ^b, T. Lopes ^c, P. Jorge ^c, N. Silva ^c, M. Kuchynka ^b,
J. Kaiser ^a

^a Central European Institute of Technology, Brno University of Technology, Purkyňova 656/123, 61200 Brno, Czech Republic

^b Department of Chemical Drugs, Faculty of Pharmacy, Masaryk University, Palackého třída 1, CZ-61200 Brno, Czech Republic

^c Center for Applied Photonics, INESC TEC, Rua do Campo Alegre 687, Porto 4169-007, Portugal

*Email: pavel.porizka@ceitec.vutbr.cz

The integration of distinct imaging modalities through data fusion is a pivotal strategy in modern analytical science, providing comprehensive insights that surpass the capabilities of individual techniques. However, the precise alignment of multimodal datasets with disparate physical origins, varying spatial dimensionalities and non-linear intensity relationships remains a significant challenge. Here, we present an automated registration framework, demonstrated on brain tissue samples, designed to robustly align high-resolution μ CT structural data with LA-ICP-MS elemental maps. Our approach leverages a differentiable optimization scheme, where affine transformation parameters are iteratively refined using Stochastic Gradient Descent (SGD) to maximize Mutual Information (MI), thereby achieving robust coregistration based solely on image intensity distributions. This methodology not only facilitates robust correlative imaging of complex soft tissues but also serves as a critical prerequisite for enabling advanced, multi-dimensional downstream data analytics.

Acknowledgement

MK and PP gratefully acknowledge the support of Czech Science Foundation (no. 25-16166S).

High-Speed KHz LIBS Imaging

C. Derrick Quarles Jr. ^{a, *}, H. B. Andrews ^b, B. T. Manard ^b, J. Petrus ^c, D. Douglas ^c,
M. Szoltysik ^d

a Elemental Scientific Inc., Omaha, Nebraska, USA

b Oak Ridge National Laboratory, Oak Ridge, Tennessee, USA

c Elemental Scientific Lasers, Bozeman, Montana, USA

d Elemental Scientific Nordics, Kristianstad, Sweden

*Email: Derrick.Quarles@icpms.com

Laser-induced breakdown spectroscopy (LIBS) has become a very popular technique for spatially determining trace and major elements. LIBS offers the ability to measure C, H, O, N, and F, which are often difficult or unattainable by laser ablation-inductively coupled plasma-mass spectrometry (LA-ICP-MS). In some examples, samples may exist with a somewhat ($>25 \text{ cm}^2$) large two-dimensional footprint while requiring spatially resolved elemental analysis. In such instances, larger samples may not be readily suitable for standard laser ablation chambers, therefore requiring a different sampling interface. Although LA-ICP-MS can perform high-speed imaging at 1,000 Hz, it requires small spot sizes and fast single pulse responses ($<10 \text{ ms}$). For larger samples, greater spot sizes are required to keep the analysis within a reasonable time frame. In this case, LIBS is the ideal choice because the laser itself is the time limiting factor for measurements.

In this work, a new, large-format, high-speed LIBS system for analyzing samples that can be as large as 500 cm^2 will be presented. This system uses a multichannel complementary metal-oxide-semiconductor (CMOS) spectrometer to collect the spectral signal from 190 to 1100 nm. The laser used in this work was a 193 nm ArF excimer laser operated at 1 KHz and with a $5 \times 5 \text{ }\mu\text{m}$ to $200 \times 200 \text{ }\mu\text{m}$ laser spot size. The samples analyzed in this work included geological, environmental, nuclear, and archaeological. These samples varied in size, from 20 cm^2 up to 400 cm^2 , resulting in an output of up to 2.5 million pixels per hour.

Neural Networks in LIBS: Perspectives, Challenges, and Opportunities

T. Aaltonen^{a, *}

a Satakunta University of Applied Sciences, Finland

*Email: toni.aaltonen@samk.fi

As LIBS applications continue to expand, the analytical demands placed on data processing and interpretation are also evolving. At the same time, advances in machine learning have opened new possibilities for handling complex spectroscopic data in more flexible and scalable ways. Among these approaches, neural-network-based methods are becoming an increasingly visible part of the discussion. This talk will explore selected perspectives on the use of neural networks in LIBS analysis, including their potential strengths, current limitations, and broader significance for the development of the field. The presentation will address questions related to performance, robustness, and practical applicability, while also considering how such methods may fit alongside more established analysis strategies.

Physics-Informed Neural Network for Qualitative Element Detection from Spark Discharge Optical Emission Spectra

D. Prochazka ^{a, b, *}, P. Pořízka ^{a, b}, J. Kaiser ^{a, b}

a Materials Characterization and Advanced Coatings, Central European Institute of Technology, Purkyňova 656/123, Brno, Czech Republic

b Faculty of Mechanical Engineering, Brno University of Technology, Technická 2 Brno, Czech Republic

*Email: David.prochazka@ceitec.vutbr.cz

Identifying elemental signatures in spark discharge optical emission spectra is often complicated, time-consuming, and typically requires a trained specialist due to overlapping lines, varying intensities, and spectral distortions. This work introduces a physics-informed neural network designed for qualitative detection of elemental presence in iron-based samples, using synthetic spectra as both training data and embedded prior knowledge.

Synthetic emission spectra are generated using a forward model that combines individual elemental line patterns with realistic instrumental broadening, intensity variations, and self-absorption. These data are used to train the network and also to initialize its first layer with spectra of selected pure elements. This initialization provides the model with a starting representation that already resembles true elemental emission signatures, offering a physically meaningful alternative to random weight initialization.

The network is fine-tuned on experimental spark discharge spectra of Fe-based materials. Compared with conventionally initialized architectures, the proposed approach demonstrates faster convergence and significantly improved reliability in detecting the presence of alloying elements, particularly those appearing with weak or partially overlapping emission lines.

These results show that embedding spectroscopic prior knowledge directly into the neural network architecture can substantially improve qualitative elemental analysis in spark optical emission spectroscopy. The method is generalizable and can be adapted to other alloy families and spectroscopic techniques.

MONOCROM S.L.

J. Kodz

Monocrom S.L., Carrer de la Vilanoveta, 6, 08800 Vilanova i la Geltrú, Barcelona, Spain
www.monocrom.com

Email: j.kodz@monocrom.com

Monocrom is a Spanish laser technology company founded in 1993 and headquartered in Vilanova i la Geltrú, near Barcelona. For over three decades, the company has established itself as a leading manufacturer and developer of high-performance laser systems, serving a broad range of scientific, industrial, and defense customers across the globe. Built on a foundation of deep photonics expertise, Monocrom combines rigorous engineering with a strong culture of innovation to deliver reliable, cutting-edge laser solutions.

The company's portfolio covers a wide spectrum of laser technologies, including diode lasers, custom laser modules, and advanced diode-pumped solid-state (DPSS) systems.

Expanding its technological offerings, Monocrom has developed Ablon, a compact nanosecond DPSS laser. This innovative system delivers high pulse energy, making it ideally suited for LIBS plasma generation and many scientific applications.

Monocrom's in-house engineering and R&D capabilities enable end-to-end development — from component design and prototyping through to full system assembly and testing. The company serves key sectors including materials processing, medical technology, remote sensing, defense, and fundamental scientific research. Their vertically integrated model ensures tight quality control and the agility to respond to highly specialized customer needs. Internationally recognized for technical excellence and long-term reliability, Monocrom continues to push the boundaries of what laser technology can achieve across industries.



LIBS and Multimodal Spectral Imaging as Enablers of Industrial Decision Support

P. Jorge ^{a, b, *}, D. Capela ^{a, b}, R. Cavaco ^b, J. Carvalho ^b, T. Lopes ^{a, b}, J. Teixeira ^{a, b},
D. Guimarães ^{a, b}, N. A. Silva ^{a, b}

a Departamento de Física e Astronomia, Faculdade de Ciências da Universidade do Porto, Rua do Campo Alegre 687, 4169-007, Porto, Portugal

b Center for Applied Photonics, INESC TEC, Rua do Campo Alegre 687, 4169-007, Porto, Portugal

*Email: pedro.jorge@fc.up.pt

LIBS and complementary spectral technologies are becoming increasingly important analytical tools for industrial applications where fast, robust and interpretable material assessment is required. However, the complexity of real operational environments often introduces significant performance challenges, including sample heterogeneity, variable measurement conditions, limited labelled data and the need for reliable decisions under time and cost constraints.

In this context, multimodal spectral imaging is emerging as a promising route towards fit-for-purpose analytical solutions. By combining complementary techniques such as LIBS, Raman spectroscopy and hyperspectral imaging with automation, computer vision and artificial intelligence, it becomes possible to exploit cross-modal synergies for improved material identification, discrimination and process-relevant decision support.

This presentation will discuss recent strategies developed to explore these synergies, with particular emphasis on multimodal data fusion, spectral knowledge transfer and teacher–student approaches across spectral technologies. Examples will be presented in different industrially relevant contexts, including mineral identification for the mining sector and the sorting or quality assessment of recycled materials in the wood¹ and glass industries.

Acknowledgments

This work is financed by Component 5 - Capitalization and Business Innovation, integrated in the Resilience Dimension of the Recovery and Resilience Plan within the scope of the Recovery and Resilience Mechanism (MRR) of the European Union (EU), framed in the Next Generation EU, for the period 2021 - 2026, within project AgendaTransform, with reference 34. This work is also funded by national funds through FCT – Fundação para a Ciência e a Tecnologia, I.P., under the support UID/50014/2025 <https://doi.org/10.54499/UID/50014/2025>.

References

¹ Diana Capela et al. “From waste to resource: LIBS methodology development for rapid quality assessment of recycled wood”, *Journal of Hazardous Materials*, Volume 489, 2025, 137493, <https://doi.org/10.1016/j.jhazmat.2025.137493>.

Recalibration of PLS models to enable quantification of low concentration plant nutrients by laser induced breakdown spectroscopy

F. Neergaard Mikkelsen^{a, b, *}

a Department of Plant and Environmental Sciences, Faculty of Science, University of Copenhagen

b FOSS Analytical A/S

*Email: fnm@foss.dk

Multi-element analysis of plant tissue is an important tool for determining plant nutrient status and optimizing fertilization strategies in agriculture. Laser induced breakdown spectroscopy (LIBS) is a promising solution for doing high throughput analysis of plant tissue. A LIBS setup consisting of a press, a searing unit, and an analyser with an Nd: YAG laser with a pulse energy of 0.15 mJ operating at a central wavelength of 1064 nm in a nitrogen (N) atmosphere was used to measure plant leaves and partial least square regression was used to build prediction models for 10 plant nutrients. While this was successful, it was also shown that quantifying nutrient concentrations in the deficiencies range for micronutrients can be challenging with LIBS.¹ Manganese (Mn) is one of the nutrients where the initial PLS model was not sufficiently precise to diagnose Mn deficiency in plants. In an attempt to correct this, 36 samples with a low concentration of Mn were used to carry out a slope-intercept correction of the predictions from the Mn model. To test the practical use of this approach wheat plants were induced with Mn deficiency, and weekly LIBS measurements were conducted to follow the development. With the slope-intercept corrected model LIBS analysis could be used to distinguish normal plants from Mn deficient plants. Furthermore, LIBS analysis could detect nutrient deficiencies before any visual symptoms developed. The results document the usefulness of the LIBS setup for plant tissue analysis and for detection of latent plant nutrient deficiencies.

References

¹ Mikkelsen, F.N., et al., *A novel LIBS method for quantitative and high-throughput analysis of macro- and micronutrients in plants*. Journal of Analytical Atomic Spectrometry, 2024. **39**(8): p. 2008–2020.

How should detection limits be defined in LIBS?

D. S. Sonoiki ^{a, *}, K. B. Kinch ^{b, c}, K. N. Jensen ^b, K. B. Damkjær ^b, O. Bang ^{a, d}, C. R. Petersen ^{a, d}

a Department of Electrical and Photonics Engineering, Technical University of Denmark, 2800 Kongens Lyngby

b FOSS Analytical A/S, 3400 Hillerød, Denmark

c Niels Bohr Institute, University of Copenhagen, 2200 Copenhagen N, Denmark

d NORBLIS ApS, 2830 Virum, Denmark

*Email: doyinsolasimbiat@gmail.com

Limit of detection (LOD) in Laser-Induced Breakdown Spectroscopy (LIBS) represents the minimum elemental concentration that can be reliably distinguished from background noise. However, reliable LOD estimation remains challenging because LIBS signals are strongly influenced by matrix effects and calibration strategies. While LOD in LIBS is commonly reported using univariate approaches that require a true blank, suitable blanks are often unavailable in complex matrices. In addition, multivariate calibration models introduce prediction uncertainty that challenges traditional LOD concepts. This raises a fundamental question: how should detection limits be defined when both instrumental noise and model uncertainty influence analytical performance? In this study, LOD estimation for a commercial LIBS instrument (FOSS MICRAL™) was evaluated using univariate and multivariate approaches for six macronutrients (Ca, K, Mg, P, Na, S) and six micronutrients (Cu, B, Mn, Al, Fe, Zn) in well-characterized forage samples. Univariate LODs were calculated from calibration curves relating representative peak intensities to reference concentrations. In the absence of a true blank, three alternative blank definitions were investigated: (i) variability across the full calibration dataset, (ii) variability from low-concentration samples, and (iii) variability from signal-free spectral regions. Multivariate LODs were estimated following the IUPAC-consistent framework of Allegrini et al.,¹ derived from the prediction uncertainty of a global PLSR model implemented on the instrument. The results show that univariate LOD values strongly depend on blank definition, with the full calibration dataset producing the highest estimates. Despite fundamentally different definitions, multivariate LOD values were generally within a factor of two of the global univariate approach. These findings demonstrate that LOD in LIBS is not purely an instrumental parameter, but a methodological construct shaped by blank definition and calibration strategy.

Funding:

Villum Fonden (project no. 00037822: Table-Top Synchrotrons) and the Danish Maritime Fund (LASER-CLEANR, no. 2022-054).

References

¹ Allegrini F.; and Olivieri A.C. *IUPAC-Consistent Approach to the Limits of Detection in Partial Least-Squares Calibration*; Analytical Chemistry, vol. 86, p.7858-7866, Aug. 2014. Publisher: American Chemical Society (ACS).

Litron Lasers Ltd. (Q-switched Pulsed Nanosecond Nd:YAG Lasers)

J. McDowell

Litron Lasers Ltd., 8 Consul Rd, Rugby CV21 1PB, United Kingdom
www.litronlasers.com

Email: jmcdowell@litron.co.uk , sales@litron.co.uk

Litron Lasers is a leading manufacturer of high energy solid-state pulsed lasers with nanosecond pulse widths. Our lasers are all designed and manufactured in Rugby, England.

With many thousands of lasers installed worldwide, the design and manufacturing integrity of our products is truly field proven. Litron's philosophy is to keep all design and a significant proportion of manufacturing in-house. As a result, all electronics, mechanics, software, optics, and chillers are designed at Litron. This structure results in not having to rely on third parties when supporting our own products, a significant customer benefit. As well as an extremely comprehensive range of standard products Litron offers the expertise to produce custom laser systems for OEM integration.

Litron manufacture one of the most comprehensive ranges of lasers for LIBS – both lamp-pumped and fully DPSS.

Nano Series – an extensive range of ultra compact and rugged, high-performance lasers.

TRLi Series – flexible, modular high energy, all resonator options and harmonics.



Abstracts

Posters

NORDIC
LIBS
2026

Elemental Identification and Quantification of Recycled Steel Samples Using LIBS

O. Crovo ^{a, *}, S. Atikukke ^a, M. Veis ^a, P. Veis ^a

a Dept. of Exp. Physics, FMPI, Comenius Univ., Mlynská dol. F2, 84248 Bratislava, Slovakia

*Email: crovo1@uniba.sk

Recycled steel is an important resource for sustainable metal production, reducing the demand for raw materials and the environmental impact associated with primary steel manufacturing. However, the chemical composition of recycled steel strongly depends on the origin and processing history of the scrap material, requiring rapid analytical techniques for elemental characterization.¹

Laser-Induced Breakdown Spectroscopy (LIBS) is a rapid and minimally destructive technique that enables elemental identification with little or no sample preparation.^{2,3} In this work, three unknown iron-based alloy samples were analyzed using LIBS to investigate their elemental composition and evaluate the applicability of the Calibration-Free LIBS (CF-LIBS) approach for manganese quantification.⁴

The plasma was generated using a Q-switched Nd:YAG laser operating at 1064 nm. Emission spectra were recorded in the 200–1000 nm range using an Echelle spectrograph (Mechelle ME5000, Andor Technology) coupled with an ICCD camera (iStar DH734, Andor Technology). Spectra were acquired by accumulating 50 laser shots with a gate delay of 500 ns and a gate width of 1000 ns.

Representative spectral regions were selected to identify Fe, Mn, and Cr emission lines, considering the spectral congestion characteristic of complex alloy matrices. Boltzmann plots were constructed using Fe I and Mn I lines to estimate the plasma temperature and assess the plasma conditions under the assumption of local thermodynamic equilibrium (LTE). The obtained plasma parameters were subsequently employed in the CF-LIBS procedure for quantitative manganese analysis.

Acknowledgements

The authors acknowledge the Scientific Grant Agency of the Slovak Republic (VEGA-1/0815/25 and 2/0120/25), the Slovak Research and Development Agency (APVV-22-0548 and APVV-23-0281) for financial support.

References

- ¹ Bringas, J. E. (2004). Handbook of comparative world steel standards (3.^a ed.). ASTM International.
- ² Cremers, D. A., & Radziemski, L. J. (2013). Handbook of Laser-Induced Breakdown Spectroscopy (2.^a ed.). John Wiley & Sons.
- ³ Z. Zhang, T. Ou, M. Wang, C. Lin, C. Lv, Y. Qin, J. Li, H. Yang, N. Zhao, and Q. Zhang, A brief review of calibration free laser induced breakdown spectroscopy, *Front. Phys.*, 10, 887171 (2022).
- ⁴ J. Yang, X. Li, J. Xu, and X. Ma, A calibration-free laser-induced breakdown spectroscopy (CF-LIBS) quantitative analysis method based on the auto-selection of an internal reference line and optimized estimation of plasma temperature, *Appl. Spectrosc.*, 72(1), 129–140 (2018).

Pilot study on Detection of Thermochemical Degradation in Thermally Modified Wood

L. Holcmanová ^{a, *}, V. Buriánek ^b, D. Prochazka ^{a, c}, P. Pořízka ^{a, c}, J. Kaiser ^{a, c}

a Central European Institute of Technology, Brno University of Technology, Purkyňova 656/123, 61200 Brno, Czech Republic

b Faculty of Civil Engineering, Brno University of Technology, Veveří 331/95, 60200 Brno, Czech Republic

c Faculty of Mechanical Engineering, Brno University of Technology, Technická 2896/2, 61200 Brno, Czech Republic

*Email: lucie.kratochvilova1@ceitec.vutbr.cz

Thermally modified wood is now commonly used in sustainable construction because of its benefits, such as moisture resistance, dimensional stability, and biological stability, without the need for additional treatments. However, thermal modification causes complex physicochemical changes in lignocellulosic structures that are difficult to measure with conventional analytical methods. Current methods, like gravimetric mass-loss measurements or wet chemical analyses, are destructive, time-consuming, and offer limited spatial information.

This pilot study presents the first results of a multimodal spectroscopic method for quasi-non-destructive monitoring of thermochemical degradation in thermally modified wood. The proposed methodology combines laser-induced breakdown spectroscopy (LIBS) and Raman spectroscopy to offer complementary elemental and molecular information about structural changes within the wood matrix. This combination provides spatially resolved information on surface layers and shows promise for rapid, in-situ quality control of modification processes and improved consistency of sustainable wood materials.

LIBS-based detection of metals in lubricating oils

S. Anjum ^{a, *}, J. Morisho ^a, M. Geiger ^a, D. Brüggemann ^a

a Department of Engineering Thermodynamics and Transport Processes, University of Bayreuth

*Email: Saquib.Anjum@uni-bayreuth.de

Machine failures in production plants cause significant downtime and cost, while oil condition monitoring is still largely based on offline laboratory analysis, delaying detection of early wear. This project aims to develop a novel inline oil analysis system using Laser-Induced Breakdown Spectroscopy (LIBS) for real-time detection of wear particles in lubricating oils. A laboratory test facility was constructed, including laser optics, spectrometer, and dedicated sample holders, and first measurements were performed on solid reference materials and particle contaminated oils with comparison to the NIST database for elemental identification.

To address the specific challenges of LIBS in liquids such as low density, bubble formation, and optical damage¹ the wear particles are first collected on filter paper using a custom designed filtration device developed with an industrial partner. The influence of filtered volume, particle loading, and laser pulse energy on LIBS signal intensity was systematically investigated, demonstrating that larger filtered volumes lead to higher signal due to increased particle capture. Detection limits down to 50 ppm were achieved for multiple metallic elements (e.g. Cu, Pb, Zn), showing the feasibility of multi-element wear monitoring in oils. To overcome challenges like low signal intensity from limited ablatable material on the filter, long filtration times, and uneven particle distribution, we integrated a rotating device combined with targeted filtration over a small area. This approach ensures homogeneous particle distribution while enabling the laser to strike fresh filtered material with each pulse, thereby enhancing signal intensity and improving measurement consistency. Future work will focus on calibration curve development and on predicting the required filtered volume for a given laser pulse energy to enable quantitative, inline condition monitoring of lubricating oils in industrial plants.

References

¹ Bol'shakov, A. A., Pandey, S. J., Mao, X. & Liu, C. *Analysis of liquid petroleum using a laser-induced breakdown spectroscopy instrument*. Spectrochim. Acta Part B At. Spectrosc. 179, 106094 (2021).

Geometry-aware radiative-transfer modeling of LIBS spectra with ray bundles in a layered LTE plume

E. Ojanen *

*Email: eetu.ojanen@live.com

In LIBS, collection optics sample plume emission along multiple viewing rays, yet forward models are often evaluated along a single line of sight through an idealized 1D plume. This work presents a practical ray-bundle forward model (“2.5D”: 1D radial plasma state plus 3D ray integration) for quantifying how collection geometry biases simulated spectra in a hemispherically layered LTE plasma. Radiative-transfer spectra are computed for each ray through the radial shells and then summed over the ray bundle. Different ray bundles represent different collection geometries, including a pencil ray, a parallel bundle, an NA-limited conical bundle, and a lens-imaged bundle.

Simulations show that changing the ray bundle alters not only total intensity but also line ratios, line widths, and self-absorption signatures, including self-reversal depth, consistent with geometry dependent mixing of hot-core emission with cooler outer-shell emission and absorption. Small offsets of the collection axis produce large changes in integrated intensity as well as measurable changes in line ratios and self-absorption metrics, making the simulated spectrum sensitive to alignment jitter in practical setups. These effects can be quantified versus NA and pointing parameters, providing a geometry-aware basis for interpreting simulated LIBS spectra. As a spatial snapshot study, this work complements time-resolved plume modeling and supports future spatiotemporal forward-model development.

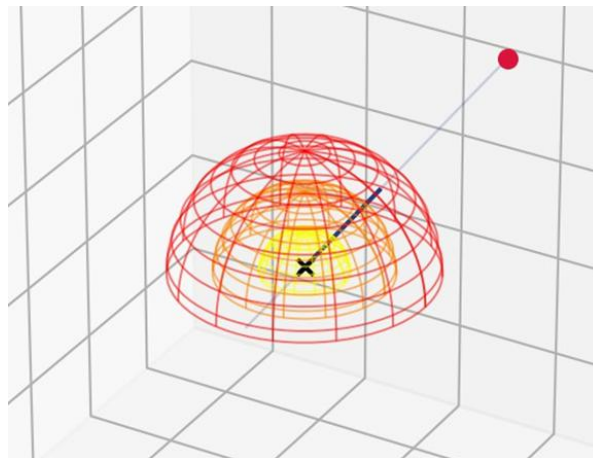

Figure 1. Hemispherically layered plume geometry with a single pencil line of sight.

Self-Supervised Latent Space Learning for LIBS Spectroscopy

T. Lopes ^{a, b, *}, D. Guimarães ^{a, b}, P. Jorge ^{a, b}, N. A. Silva ^{a, b}

a Departamento de Física e Astronomia, Faculdade de Ciências da Universidade do Porto, Rua do Campo Alegre 687, 4169-007, Porto, Portugal

b Center for Applied Photonics, INESC TEC, Rua do Campo Alegre 687, 4169-007, Porto, Portugal

*Email: tomas.j.lopes@inesctec.pt

Laser-induced breakdown spectroscopy (LIBS) has been gaining increasing attention for inline industrial analysis,¹ where large volumes of spectra can be continuously acquired during operation. However, action on LIBS datasets still largely relies on supervised classifiers, which require labeled spectra that are costly to obtain and often underperform at capturing process variability, matrix effects, instrumental drift, and evolving measurement conditions. In this work, we propose a self-supervised teacher-student framework for learning latent representations of LIBS spectra from unlabeled data, inspired by recent Siamese and DINO-like representation learning approaches.

Rather than treating unlabeled spectra as samples awaiting prediction, the proposed methodology uses them as the primary source of structure for representation learning. Different augmented views of the same spectrum are processed by the teacher and student networks, which are trained to produce consistent latent-space representations. Through this objective, the model learns spectral embeddings that preserve chemically and physically meaningful information while becoming more robust to intensity fluctuations, baseline variations, noise, and other acquisition-dependent effects commonly observed in LIBS measurements.

The resulting latent space provides a compact representation, enabling downstream classification, clustering, drift monitoring, and process tracking with reduced reliance on labeled datasets. This is particularly relevant for inline industrial deployment, where spectra are continuously generated and can be incorporated into the learning process during operation. This framework offers a path toward adaptive, label-efficient, and continuously improving LIBS analysis systems for industrial environments.

Acknowledgments

This work is financed by Component 5 - Capitalization and Business Innovation, integrated in the Resilience Dimension of the Recovery and Resilience Plan within the scope of the Recovery and Resilience Mechanism (MRR) of the European Union (EU), framed in the Next Generation EU, for the period 2021 - 2026, within project AgendaTransform, with reference 34. This work is also funded by national funds through FCT – Fundação para a Ciência e a Tecnologia, I.P., under the support UID/50014/2025 <https://doi.org/10.54499/UID/50014/2025> and through Grant 2024.01830.BD.

References

¹ Diana Capela et al. “From waste to resource: LIBS methodology development for rapid quality assessment of recycled wood”, *Journal of Hazardous Materials*, Volume 489, 2025, 137493, <https://doi.org/10.1016/j.jhazmat.2025.137493>.

Micro-discharge system for OES training data collection

J. Rouhiainen ^{a, *}, P. Suominen ^a

a RoboAI R&D Centre, Satakunta University of applied sciences, Pori, Finland

*Email: joonas.o.rouhiainen@samk.fi

In this poster, we present a micro-discharge system for collecting emission spectra to train neural network models for elemental analysis. In machine-learning applications of laser-induced breakdown spectroscopy, obtaining sufficiently large datasets with varying elemental compositions can be challenging. Preparing controlled solid alloy samples is labor-intensive, and commercially available metal mixtures provide only a limited range of compositions. Liquid samples with controlled elemental concentrations can be prepared easily by dissolving known quantities of sulfates into solution.

In the presented system, plasma is generated directly in liquid samples using a high-voltage electrical discharge instead of laser excitation. The method is designed specifically for liquid analysis. A sample is first drawn from the source, and its electrical conductivity is adjusted using acid. The solution is then introduced into a flow cell containing two opposing tungsten electrodes. When the cell is filled, a high-voltage pulse is applied across the electrodes, producing plasma between the electrodes. The emission spectrum from the plasma is collected for analysis. To ensure the system is not contaminated, after each measurement the system is flushed with deionized water before introducing the next sample.

The discharge pulse is generated using a capacitor bank, a high-voltage power supply, and a fast high-voltage transistor switch. This configuration enables repeatable plasma formation in liquid and provides a practical way to generate large spectral datasets with controlled elemental concentrations for machine-learning-based spectroscopic analysis.

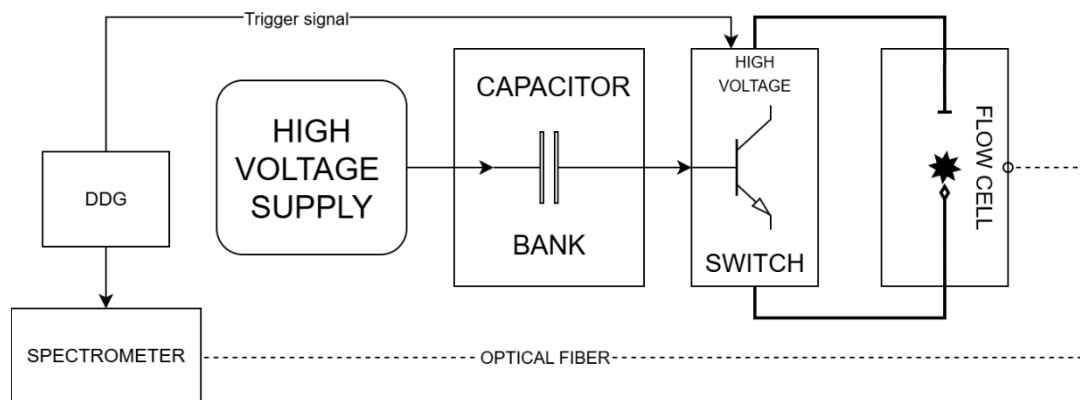

Figure 1. Simplified setup.

An Interactive Online Platform for the Simulation and Analysis of LIBS

Y. Wang ^{a, *}, S. Zhang ^a, T. Aaltonen ^a, P. Suominen ^a

^a *RoboAI R&D Centre, Satakunta University of Applied Sciences, Pori, Finland*

*Email: yilin.wang@samk.fi

Physics-based OES/LIBS simulation supports spectral interpretation, method development, and synthetic dataset generation, but practical reuse is often limited by installation effort or lack of scalable interfaces. We present a service layer that exposes the SAMK in house developed OES simulator as a free, hosted resource for the community. The contribution is not a new simulator model; rather, it focuses on making our previously developed simulator easy to access, configure, and run in both interactive and programmatic workflows.

The service includes (1) a browser-based application with interactive visualisation and (2) a pip-installable Python package that provides a stable API for automated parameter sweeps and bulk requests. Users can define the material matrix/composition, set bounds for electron temperature (T_e) and electron density (N_e), and select or provide cooling functions. The interface supports multi-layer plasma descriptions, allowing users to specify the number of layers, their respective spatial dimensions, and the specific T_e/N_e ratios between layers to simulate plasma inhomogeneities accurately. Furthermore, users can control the instrumental response settings to generate realistic simulated device outputs. Outputs can be retrieved as CSV for quick inspection or HDF5 for large-scale, structured datasets, together with metadata to ensure reproducibility.

We will demonstrate the web interface and Python workflow, highlighting how large numbers of spectra can be generated efficiently for benchmarking chemometric pipelines and training machine-learning models.

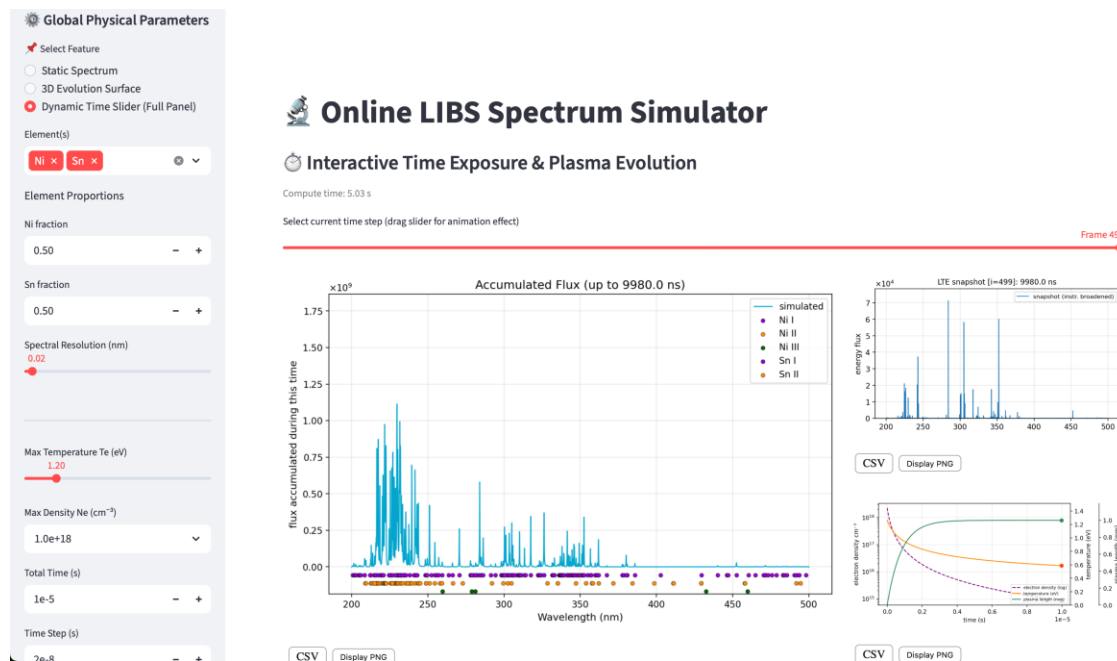

Figure 1. LIBS Spectral Simulation Interface for ROSS Project.

'Laserless LIBS' – Dielectric barrier discharge plasma-induced emission spectroscopy (DBD-IES)

C. Gerhard ^{a, *}

^a University of Applied Sciences and Arts, 37085 Göttingen, Germany

*Email: christoph.gerhard@hawk.de

Even though LIBS is a powerful and easy-to-use analysis method, it is subject to certain limits. For instance, thinnest surface-adherent layers are challenging to measure due to the comparatively high ablation and information depth. In this contribution, a LIBS-like approach, based on a dielectric barrier discharge (DBD) plasma as excitation source, is introduced. In contrast to the comparable method of ICP-AES, the applied plasma operates at low temperature in the range of merely some tens of centigrade.¹ As shown in the present work, this allows the analysis of thinnest films with a thickness of some monolayers and temperature-sensitive material surfaces.² Moreover, the advantages of coupling the presented method with classical LIBS such as an increased sensitivity³ are introduced and discussed.

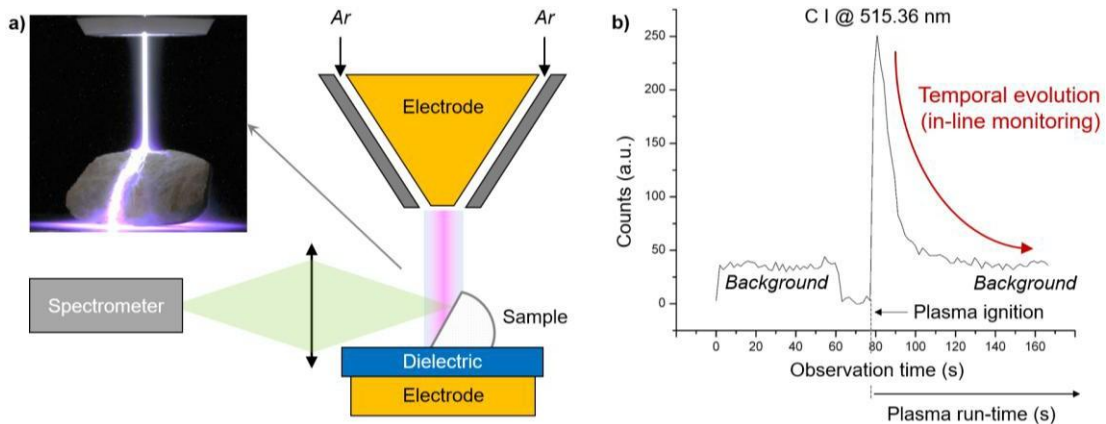

Figure 1. Setup for DBD-IES (a) and example for the measurement of time-dependency of carbon contaminants on surfaces (b).

References

- ¹ A. Gredner, C. Gerhard, S. Wieneke et al.: Increase in generation of poly-crystalline silicon by atmospheric pressure plasma-assisted excimer laser annealing, *Journal of Materials Science and Engineering B* 3 (2013) 346-351.
- ² S. Brückner, S. Rösner, C. Gerhard et al.: Plasma-based ionisation spectroscopy for material analysis, *Materials Testing* 53 (2011) 639-642.
- ³ C. Gerhard, S. Roux, F. Peters et al.: Hybrid laser ablation of Al₂O₃ applying simultaneous argon plasma treatment at atmospheric pressure, *Journal of Ceramic Science and Technology* 4 (2013) 19-24.

ESTER: A 60 mJ Compact Air-Cooled Q-Switched Nd:YAG Laser for Field Deployment

K. Polak ^{a,*}, A. Fajstavr ^a, M. Chyla ^b, M. Zacek ^b

^a *Crytur, spol. s r.o., Turnov, Czech Republic*

^b *HiLASE Centre, Institute of Physics CAS, Dolní Břežany, Czech Republic*

*Email: krystof.polak@crytur.cz

A compact, air-cooled Q-switched Nd:YAG laser producing 10 ns pulses at 1064 nm has been realized, delivering more than 60 mJ at 50 Hz or 50 mJ at 100 Hz. The system incorporates a patented pump homogenization module and fully integrated electronics, all supplied from a single 24 V DC source. Outstanding pulse stability is achieved, with <0.3 % RMS power variation and <0.5 % energy fluctuation. Spatial beam profiles and key performance metrics are presented in Figure 1. The laser is ideally suited for LIBS, LIDAR, and nonlinear optics in demanding field environments.

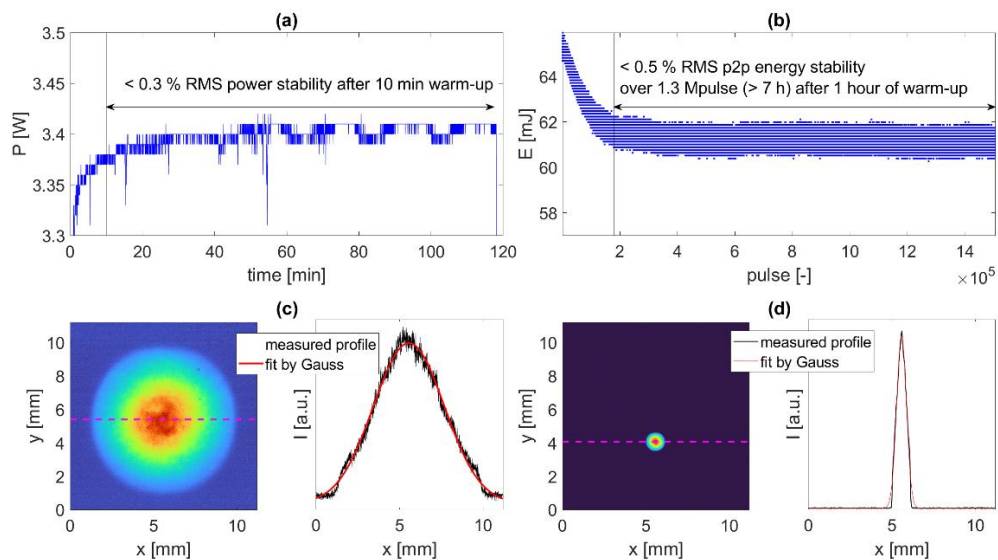

Figure 1. (a) Output power stability over time; (b) pulse energy over 1.5×10^6 shots; (c) near-field distribution; (d) far-field distribution.

Acknowledgements

This work was supported by Technology Agency of the Czech Republic (TAČR) under TREND programme, project FW03010298 – Build a portfolio of new optoelectronic products, with co-funding from the Ministry of Industry and Trade of the Czech Republic.

Laser sources for LIBS applications

G. Kudaba

EKSPLA, Savanoriu av. 237, LT-02300 Vilnius, Lithuania
www.ekspla.com

Email: g.kudaba@ekspla.com , sales@ekspla.com

EKSPLA is an innovative manufacturer of solid-state and fiber lasers, from customized systems to small and medium OEM series. The ability to tailor the product for specific applications and/or according to specific OEM requirements is one of the main strengths of EKSPLA.

For customers, who need reliable laser equipment designed for long-term operation and delivered on time, EKSPLA provides optimized and tailored solutions for specific requirements that enables customers' product or research to be unique. For this reason, we are leading in the global market for scientific picosecond lasers.

Employing latest achievements in laser technologies, team of dedicated engineers designed wide range of products tailored for specific applications: from compact, simple and robust DPSS nanosecond NL200 series lasers for OEM manufacturers to high energy customized flash-lamp or diode pumped multijoule systems for research laboratories.

Main products include high pulse energy lasers, ultrafast and nanosecond tunable wavelength lasers, laser electronics, high intensity laser systems.

Utilization of 3D-printed support for LIBS analysis of liquids

S. Živković ^{a,*}, I. Čechová ^b, J. Buday ^b, P. Pořízka ^b, J. Kaiser ^b, M. Momčilović ^a, G. Galbács ^c

^a VINČA Institute of Nuclear Sciences – National Institute of the Republic of Serbia, University of Belgrade, P.O. BOX 522, 11000 Belgrade, Serbia

^b Central European Institute of Technology (CEITEC), Brno University of Technology, Purkyňova 123, 612 00 Brno, Czech Republic

^c Department of Molecular and Analytical Chemistry, University of Szeged, Dóm sq. 7-8, 6720 Szeged, Hungary

*Email: sanjaz@vin.bg.ac.rs

In this study, a 3D-printed support system was developed for LIBS analysis of liquid environmental samples. Nanomaterials, specifically cellulose and gold nanoparticles, were incorporated into the samples to mitigate the coffee ring effect. Using the LIBS Firefly system (Lightigo, Czech Republic), 3D-printed sample holders containing dried sample residues were analyzed. The homogeneity of dried drops was first evaluated through LIBS mapping. Initial findings demonstrated that adding nanocellulose, either alone or combined with gold nanoparticles, significantly enhanced the uniformity of the mapped areas. Subsequently, the standard addition method was utilized to quantify analyte concentrations in liquid samples. The addition of nanomaterials notably improved the regression coefficients, with the highest values achieved when both cellulose and gold nanoparticles were used together.

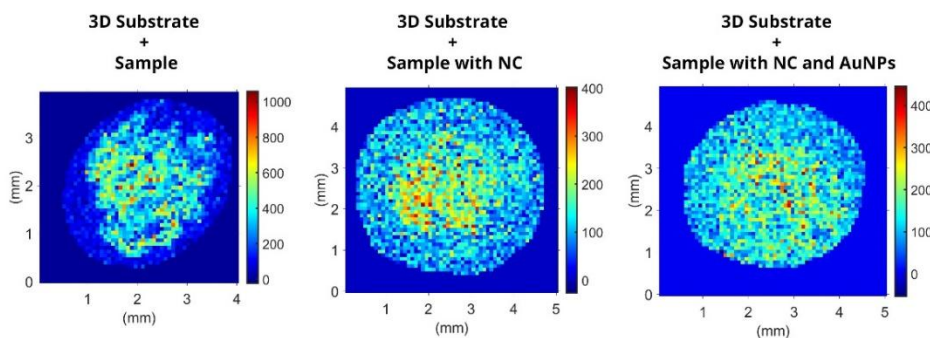

Figure 1. LIBS maps of copper distribution

Acknowledgements

This project has received funding from the European Union's Horizon Europe research and innovation programme under grant agreement No 101131765 (EXCITE²) for Transnational Access conducted at The Laboratory of Laser spectroscopy, Central European Institute of Technology and it was funded by the Ministry of Science, Technological Development and Innovation of the Republic of Serbia (Contract number: 451-03-33/2026-03/200017 and Multilateral Scientific Cooperation in the Danube Region between Serbia, Bulgaria and Czech Republic Contract number: 003614304 2025 13440 003 000 000 001 01 011).

Depth-Resolved Detection of Deuterium in Tungsten-Based Materials Using High-Resolution LIBS

S. Atikukke ^{a, *}, M. Veis ^a, P. Ďurina ^a, E. Grigore ^b, F. Baiasu ^b, P. Veis ^a

^a FMPI, Comenius Univ., Mlynská dol. F2, 842 48, Bratislava, Slovakia

^b NILPRP 409, 077125 Magurele, Romania

*Email: sahithya.atikukke@fmph.uniba.sk

Deuterium retention in plasma-facing materials is a key issue for the operation of future fusion reactors and requires reliable diagnostic techniques for depth-resolved analysis.¹⁻⁶ In this work, high-resolution Laser-Induced Breakdown Spectroscopy (LIBS) was employed to investigate deuterium-containing tungsten-based samples. Measurements were performed using a nanosecond Nd:YAG laser (Big Sky Quantel, 30 mJ) in an AtomTrace chamber under low-pressure argon atmosphere. Plasma emission in the H α spectral region was recorded using a HORIBA Jobin Yvon THR 1500 spectrometer coupled to an Andor Newton EMCCD detector.

The spectroscopic system was calibrated using Hg/Ar emission lines, enabling precise determination of the wavelength separation between H α and D α . A distinct D α emission feature was observed at the expected spectral position relative to H α and was consistently detected in repeated measurements. The D α signal gradually decreased and disappeared after approximately 50 consecutive laser shots, while the H α signal remained present, indicating depletion of deuterium from the analysed layer and demonstrating the depth-resolved capability of the technique.

The ablation rate was determined using confocal microscopy measurements of the laser-induced craters, allowing the analysed depth to be correlated with the number of laser shots. The results demonstrate the potential of high-resolution LIBS for deuterium detection and depth profiling in fusion-relevant tungsten-based materials and support its application for fuel-retention diagnostics in future fusion devices.

References

- ¹ P. Veis et al., *Nucl. Mater. Energy* 2020, 25, 100809.
- ² S. Almviva et al., *Fusion Engineering and Design*, vol. 146, 2019.
- ³ S. Atikukke et al., *Nucl. Mater. Energy* 2024, 38, 101558.
- ⁴ I. Traparic et al., *Spectrochimica Acta - Part B Atomic Spectroscopy* 2024, 221 107050.
- ⁵ H. J. van der Meiden et al., *Nucl. Fusion* 2021, 61, 125001.
- ⁶ S. Soni et al., *Spectrochimica Acta - Part B Atomic Spectroscopy* 2024, 216, 106930.

LIBS at nJ Pulse Energy with GHz repetition rate, burst mode Yb fiber laser

A. Noor ^a, P. Elahi ^{a, b, *}

a Department of Electrical and Electronics Engineering, Özyeğin University, Istanbul 34794, Türkiye

b Department of Natural and Mathematical Sciences, Özyeğin University, Istanbul 34794, Türkiye

*Email: parviz.elahi@ozyegin.edu.tr

Laser-induced breakdown spectroscopy (LIBS) using GHz burst-mode pulses offers a promising route toward high-speed, low-damage elemental analysis. Here, we present LIBS in the ablation-cooled regime using a home-built Yb-doped fiber laser operating at a 2.8 GHz intra-burst repetition rate and a 100 kHz burst repetition rate.

We performed LIBS on 303 stainless steel at burst durations of 83, 120, and 240 ns, corresponding to 232, 336, and 672 pulses per burst, and investigated them at individual pulse energies of 9–196 nJ. The 83 ns burst produced the highest signal-to-noise ratio, sharp emission lines, and minimal continuum background, while longer bursts led to stronger thermal effects and blackbody-like emission. Plasma diagnostics yielded electron temperatures of 2050, 1902, and 1708 K and electron densities of 1.959×10^{17} , 1.874×10^{17} , and $1.386 \times 10^{17} \text{ cm}^{-3}$ for 83, 120, and 240 ns bursts with 45.5 μJ burst energy, respectively.

We then extended this approach to highly reflective material like copper², where stable Cu I and Cu II emission was achieved at only 74 nJ incident pulse energy. Owing to $\sim 97\%$ reflectivity at 1030 nm, the absorbed energy per pulse was below 3 nJ, the electron temperature was calculated as 10283 K, and the electron densities were $4.02 \times 10^{16} \text{ cm}^{-3}$.

These results demonstrate that GHz burst-mode fiber lasers can enable fast, minimally damaging, and potentially macroscopically non-destructive LIBS.

References

¹ Noor, A.; Hasar, E.; Elahi, P. *Micro-laser-induced breakdown spectroscopy using GHz repetition rate pulses at nJ pulse energy*. J. Phys. Photonics 2026, 8, 015012.

² Noor, A.; Elahi, P. *Laser-Induced Breakdown Spectroscopy of Copper Using a Yb-Doped Fiber Laser with a 2.8 GHz Intra-Burst Repetition Rate*. Preprint at Optica Open 2026.

Challenging LIBS matrix effects in Cu-rich raw materials; quantification with multivariate calibration and CF-LIBS

J. Meima ^{a, *}, K. Berkh ^b

a Federal Institute for Geosciences and Natural Resources (BGR, Hannover, Germany)

b Institute for Geosciences, Friedrich-Schiller-University (FSU, Jena, Germany)

*Email: jeannet.meima@bgr.de

This study investigates a set of samples with challenging LIBS matrix effects. The aim is to quantify Cu concentrations using LIBS and also to understand the nature of these matrix effects. Thereto, multivariate calibration as well as CF-LIBS were applied.

The investigated samples consist of pulverized Cu concentrates and ores with Cu concentrations of up to 40 wt.%. In some samples, the primary Cu-minerals including chalcopyrite (CuFeS_2), enargite (Cu_3AsS_3), and tennantite ($\text{Cu}_{12}\text{As}_4\text{S}_{13}$) have been partially altered by weathering into secondary Cu minerals such as brochantite ($\text{Cu}_4(\text{SO}_4)(\text{OH})_6$). Other main minerals are pyrite (FeS_2) and quartz (SiO_2). Additional samples for multivariate calibration were prepared by mixing original Cu concentrates and ores in different proportions. All 72 samples were subsequently homogenized and pressed into pellets. Chemical reference analyses were performed using ICP-OES and μ -XRF.

LIBS spectra for multivariate calibration were collected using an echelle spectrometer with a CCD detector (210–1000 nm, spectral resolution 4500). LIBS spectra for CF-LIBS were acquired using an echelle butterfly spectrometer with an ICCD detector (220-405 and 400-770 nm, spectral resolution 22000), which were subsequently calibrated using a deuterium and halogen source. The complete surface of the pellets was measured with LIBS, and the mean of the collected LIBS spectra was used for subsequent quantitative analysis.

The raw LIBS spectra do not show positive correlations with Cu or Fe concentrations for non-resonant Cu and Fe lines. For some samples, correlations are even negative. Despite these pronounced matrix effects, the results for multivariate calibration appear surprisingly good, although they should be interpreted with caution. CF-LIBS is currently being applied for quantification purposes and to further investigate the nature of these matrix effects.

LIBS Analysis of Heavy Metal in Lipsticks: Advancing Cosmetic Safety Standards

D. Kumari ^a, V. Dwivedi ^{b, c, *}, G. S. Maurya ^{d, **}

a Faculty of Chemical Sciences, Shri Ramswaroop Memorial University, Barabanki 225003, U.P., India

b Department of Agroecology, Aarhus University, Blichers Alle 20, 8830 Tjele, Denmark

c Photonics Laboratory, Physics Unit, Tampere University, Korkeakoulunkatu 3, 33720 Tampere, Finland

d Faculty of Physical Sciences, Shri Ramswaroop Memorial University, Barabanki 225003, U.P., India

*Email: vishal.dwivedi@agro.au.dk

** gulabsmaurya@gmail.com

Lipsticks is a widely used cosmetic product, often contain trace amounts of toxic heavy metals that pose potential health risks with prolonged exposure. This study employs Laser-Induced Breakdown Spectroscopy (LIBS) as a rapid, sensitive, and non-destructive technique for detecting and analyzing heavy metal contaminants in various lipstick samples. The LIBS technique enables real-time elemental analysis, identifying hazardous metals such as Bismuth (Bi), Mercury (Hg), Barium (Ba), Cadmium (Cd), Iron (Fe), Manganese (Mn), Chromium (Cr), Vanadium (V), Scandium (Sc), Titanium (Ti) and Aluminum (Al), which may originate from raw materials or manufacturing processes. Our findings highlight the presence and relative concentration levels of these toxic elements, emphasizing the necessity of stringent quality control measures in the cosmetic industry. The study further underscores the advantages of LIBS in ensuring product safety and regulatory compliance. By providing an efficient approach for heavy metal detection, this research contributes to advancing cosmetic safety standards and promoting consumer health awareness.

Phosphorus prediction in agricultural soils using LIBS

V. Dwivedi ^{a, *}, S. Sánchez-Esteva ^a, A. Wangeci ^a, D. Adén ^b, G. Heckrath ^a, M.H. Greve ^a,
M. Knadel ^a

a Department of Agroecology, Aarhus University, Blichers Allé 20, 8830 Tjele, Denmark
b FOSS Analytical A/S, Nils Foss Allé 1, 3400 Hillerød, Denmark

*Email: vishal.dwivedi@agro.au.dk

Accurate quantification of soil phosphorus (P) across different pools is essential for soil health assessment and sustainable nutrient management. As the conventional laboratory analyses are often costly, time consuming, and unsuitable for large scale applications, this study assesses the potential of laser-induced breakdown spectroscopy (LIBS) for predicting total P, oxalate-extractable P, Olsen P, and water-extractable P in Danish agricultural soils (topsoil and subsoil).¹ The samples were dominated by coarse-textured soils, ranging from sand and loamy sand to sandy loam and sandy clay loam. A total of 533 samples were air-dried, sieved (<2 mm), and analyzed using a laboratory-scale LIBS system (FOSS). Chemometric models partial least squares regression (PLSR) and support vector regression (SVR) were developed using spectral data and reference values obtained from wet chemical analysis, with 80% of samples used for calibration and 20% for validation. Predictions with high accuracy (R^2 up to 0.90) for cross-validation and independent validation were achieved. The used approach shows clear potential for quantifying P pools in agricultural soils, providing meaningful predictions even in complex matrices.

References

¹ Sánchez-Esteva, S., Knadel, M., Labouriau, R., Rubæk, G.H. & Heckrath, G. 2021. Total Phosphorus Determination in Soils Using Laser-Induced Breakdown Spectroscopy: Evaluating Different Sources of Matrix Effects. *Applied Spectroscopy*, 75, 22–33.



AARHUS
UNIVERSITY
DEPARTMENT OF AGROECOLOGY

NORDIC LIBS 2026



Editing
&
Design

Dr. Vishal Dwivedi
Aarhus University, Denmark

24-25 June, 2026